



ASSEMBLY MANUAL

Part 1 - Welding

Phoenix 400 all configuration – Version 2022

HHO-Canada Inc

2883 Rue King Est, door 3

J1G5J1 Sherbrooke, QC, Canada

Tel : (+1) 819-574-5192

Email : contact.hho.canada@gmail.com

Last update : 25/01/2022 13:06

Introduction

Before starting the assembly, please check the entire pallet to see if there are no missing parts. It is important to carefully read the entire manual before the beginning of the assembly in order to avoid any mistake or misunderstanding.

The assembly process has been simplified as much as possible, if you have any doubt, do not hesitate to contact us. We are available from Monday to Friday 8.30 am to 12am and 2pm to 5pm, by phone or mail (with picture if possible).

If a part seems damaged or non-compliant, please send us a picture by mail for verification. For any after sale service, please contact us by mail with the problem you have, along with a picture if possible, your address, phone number and the invoice number.

Do not hesitate to send us your remarks or suggestions to improve this manual and help us improve the quality of the service we offer.

We wish you well on the assembly and do not hesitate to contact us.



Welding step by step

All the blueprints of the PH400 are present at the end of this document

Base frame

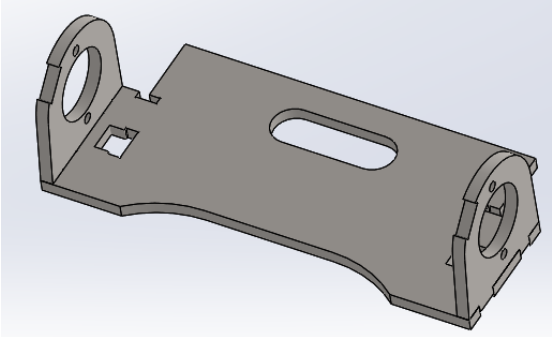
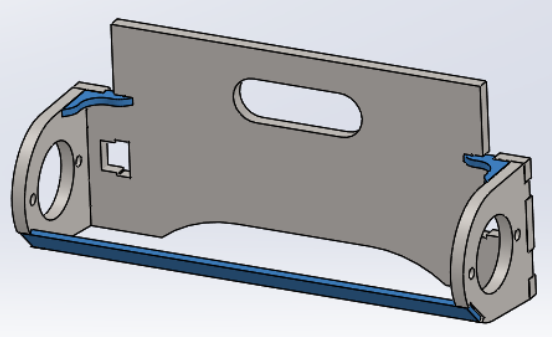
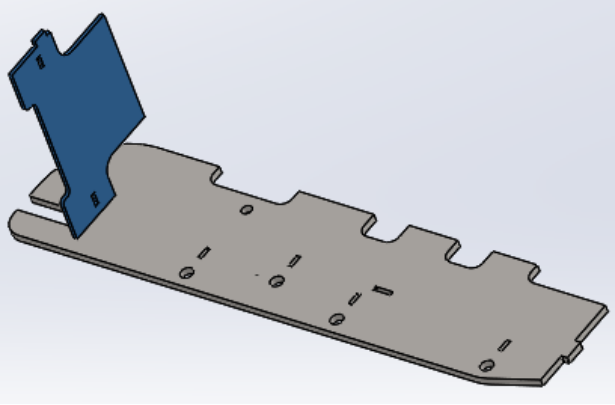
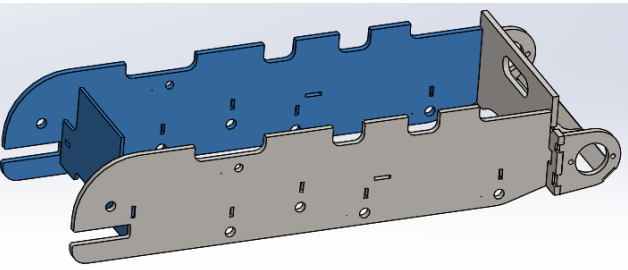
	<p>Tack the hydraulic motor supports to the back plate.</p>
	<p>Check for squareness and tack the hydraulic motor reinforcements and the 2 brackets.</p> <p>Put it aside for the next step.</p>
	<p>Tack the front plate to one of the side plates.</p>
	<p>Tack the everything together.</p>

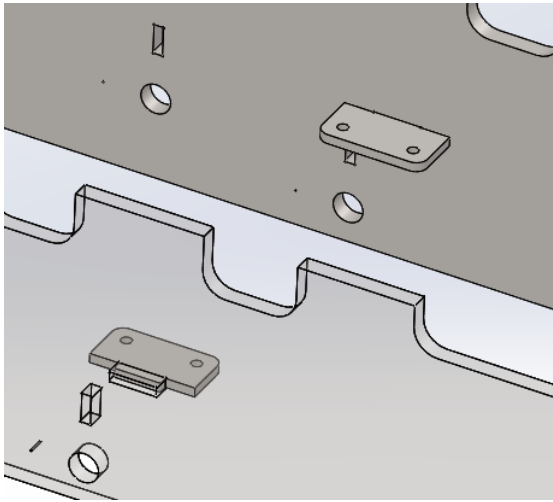

Weld strongly the 2 center brackets inside the frame.

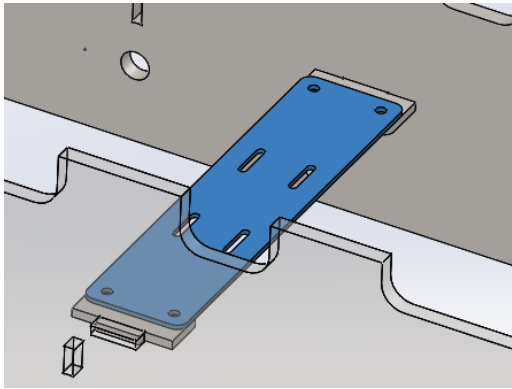

Screw in the support plate to maintain the spacing while welding

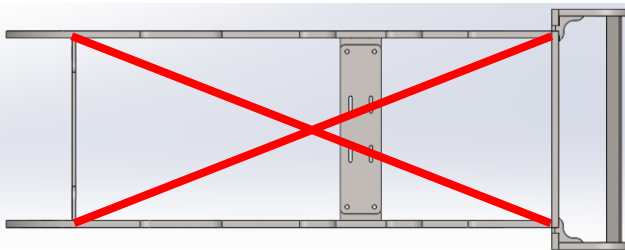

Check for squareness by measuring the diagonals; max difference of 2 mm

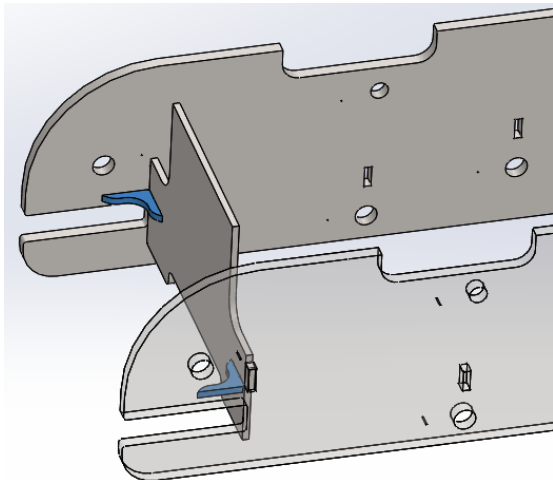

Tack the 2 brackets to the front of the frame.

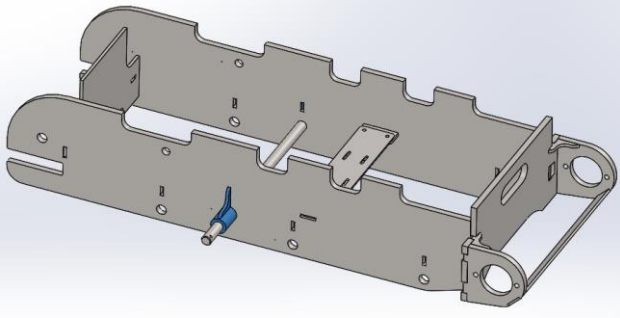

Weld the 2 $\varnothing 25$ lg 60 bushings with a bracket on top while guiding them with a free shaft (do not weld the shaft).

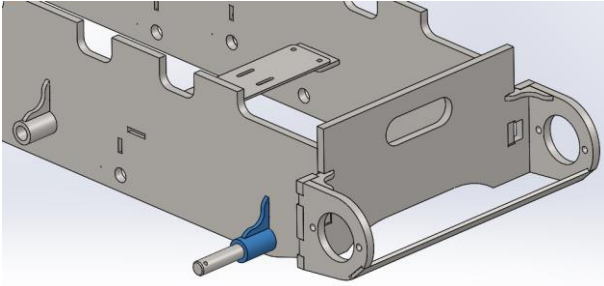

Repeat the same thing for the 2 $\varnothing 25$ lg 65 bushings at the rear of the frame.

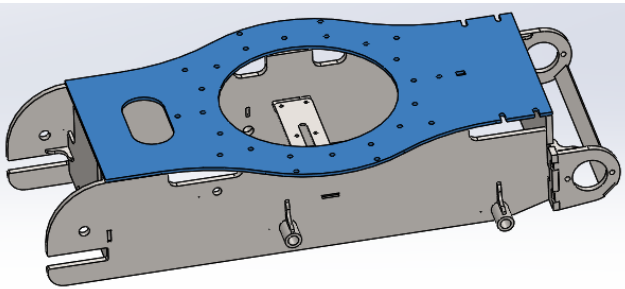

Check on last time the diagonals for squareness then tack the to plate to the base.

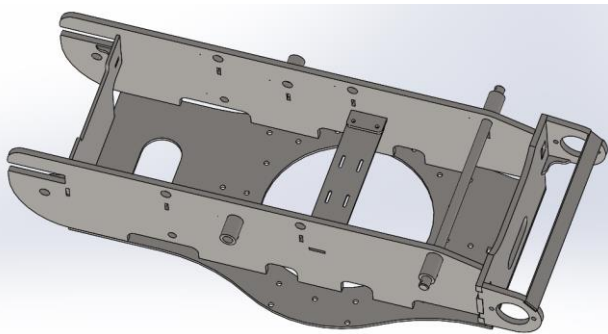

You can now weld the entire base frame.
It is advised to turn over the frame and do most of the welds from the inside.
Do not forget to put a shaft in through the bushing to minimise the deformations while welding.

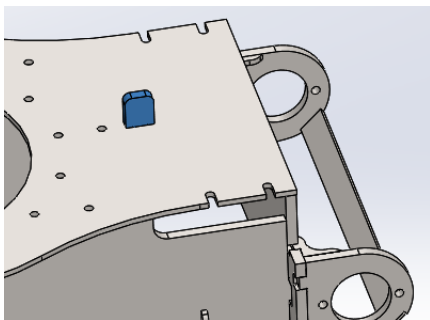

Last step for the base frame is to weld the stopper on top of the plate.

Front blade

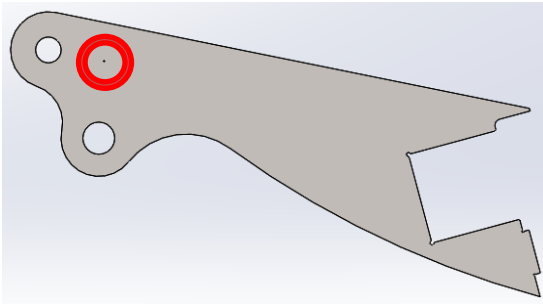

Before tacking, you need to drill and tap the blade fixations in order to lock the teardrop shafts.

Drill one hole with a Ø5.2 or 5.5mm bit and a M6 tap.
Repeat this operation on the 4 plates to avoid any mistakes.

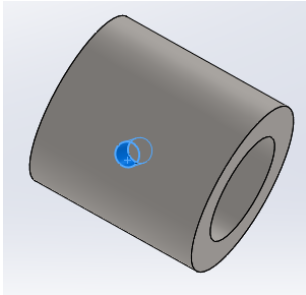

Drill and tap the 2 Ø25 lg 41 bushing that will be used later.

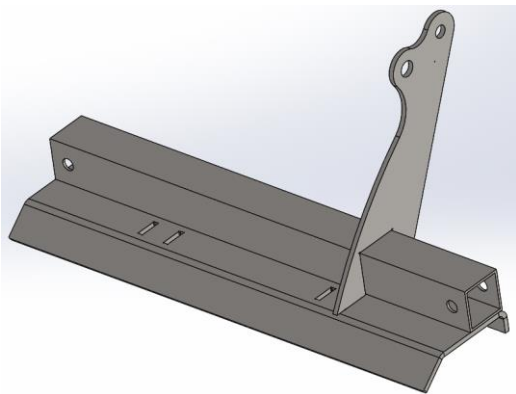

Place and tack the first support square on the blade on the first mortise.

Pay attention to the position of the holes on the tube.

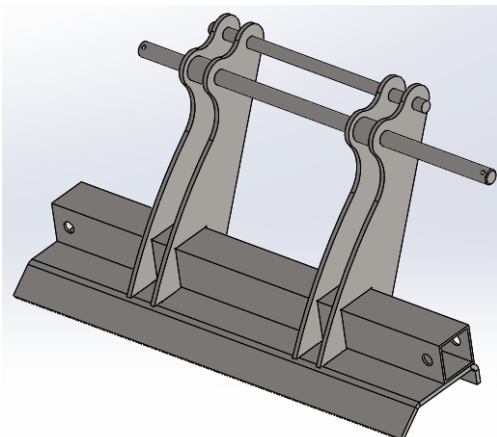

Tack the other 3 support by aligning them with 2 shafts.

Tack 2 Ø25 lg 41 bushings between the supports; with the tap facing the front of the blade, a grease fitting will be placed here and should be easily accessible once the excavator is assembled.

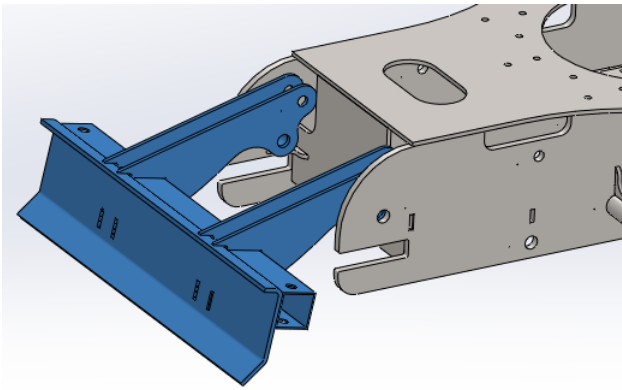

Before welding, check if the blade fit properly in the base frame.
There should be a gap of 1 to 2 mm from the frame.

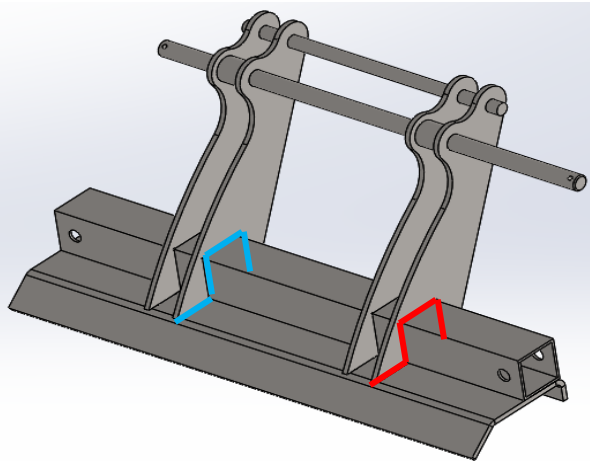

Once everything has been checked, put the shafts back on to minimise the movement while welding.

There is no need to weld between the support where the torch does not fit; outside welds are enough.

Be careful not to deform the blade while welding.

Tensioner shaft

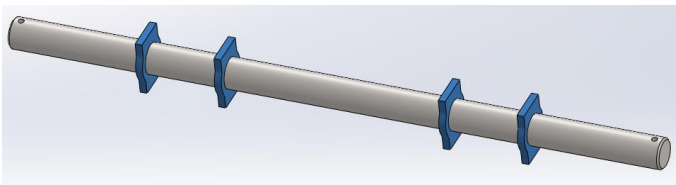

Trace the center of the tensioner shaft and place the 4 stop brackets.

Space 2 of them 250 mm away from the center
Space 2 of them 432 mm away from the center

Only tack on the outside of the exterior brackets

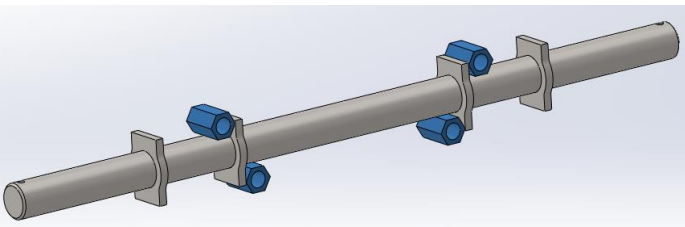

Tack the long M16 nuts

2 on the outside face of the center brackets
2 on the inside face of the center bracket

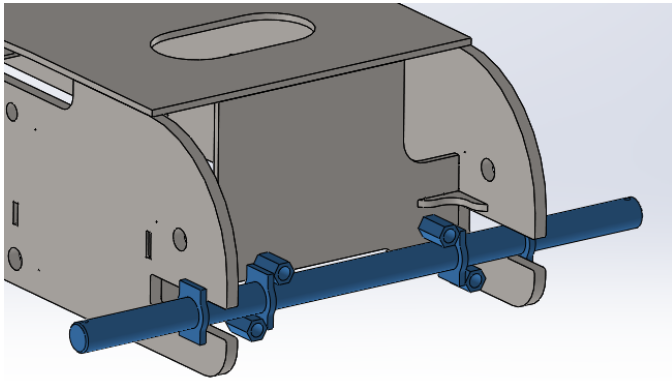

Check if the shaft fits in the front of the frame
Warning, when finishing the weld of this part do not weld :

- The parts that will be in contact with the frame
- The tap of the M16 nuts

The turret

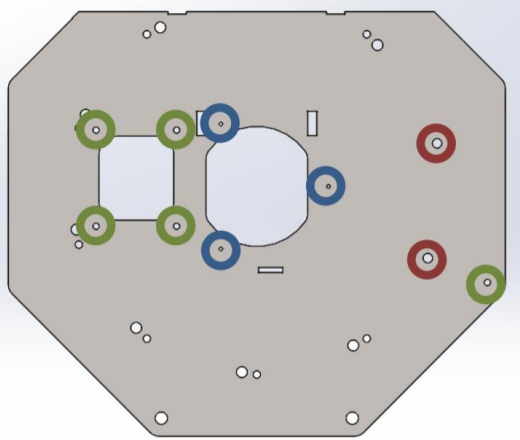

Before begging welding, you need to drill and tap the turret :

M8 for the blue circles
M12 for the green circles
M18 for the red circles

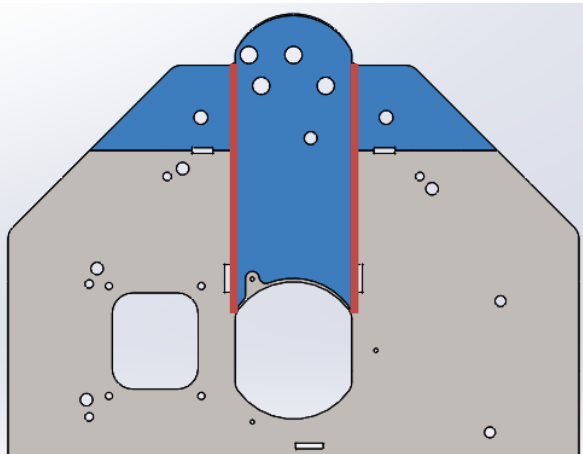

Tack the front plate and the reinforcement of the base of the turret.

Be careful of the side by looking at the holes.

Do not tack the edges in red.

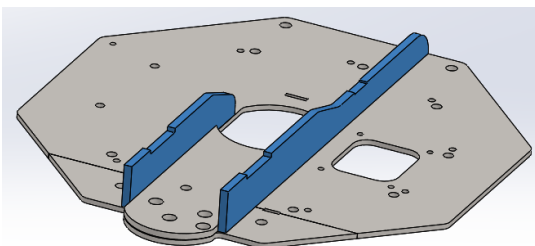

Tack the 2 lateral reinforcements.

If it is curved, straighten is as much as possible.

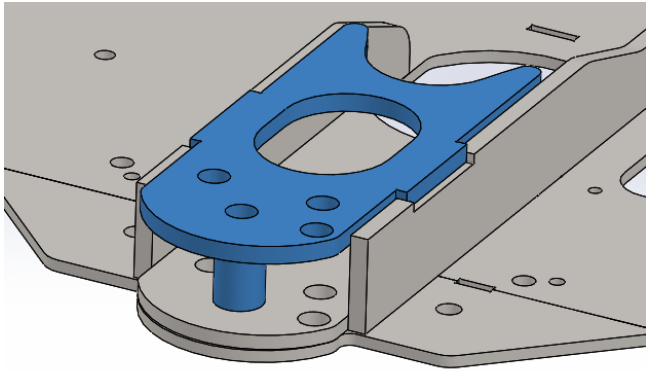

Tack the upper reinforcement with a $\varnothing 25$ lg 60 bushing.

Align the holes with shafts to be sure of the position of the plate.

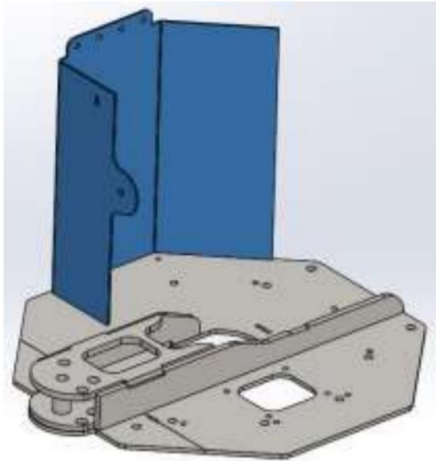

Tack the tank casing on the base of the turret by aligning the bent edges with the edges of the turret.

Be careful that the mortise is on the top of the casing.

Weld the interior of the casing with a waterproof weld.

Leave a 10mm gap in the weld at the end of the casing for later.

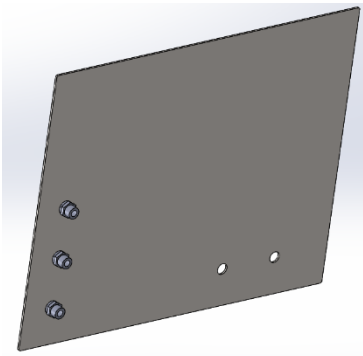

On the side tank plate, weld 3 UM12L-12x17 fitting, the o-ring side on the metal in order to connect the 12L fitting of a hose on it.

Warning, take off the o-ring before welding.

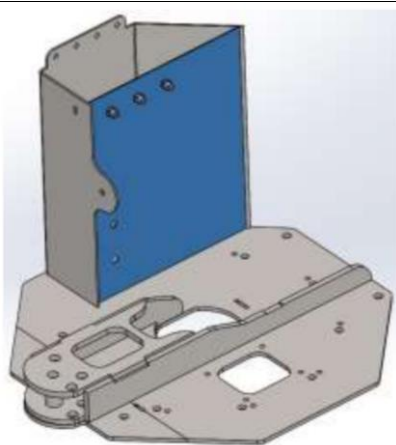

Place the side tank plate with a 5mm gap in order to have a waterproof weld more easily.

Weld the tank from the inside and the outside.

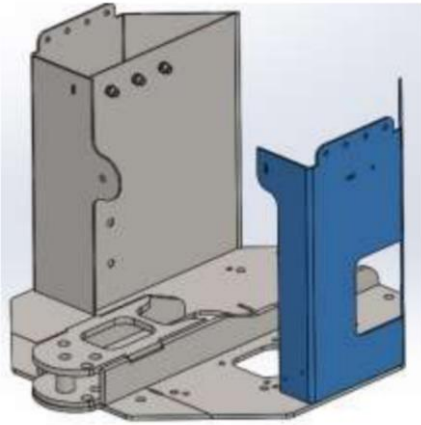

Tack the second casing.
Tack only the inside (aesthetic)

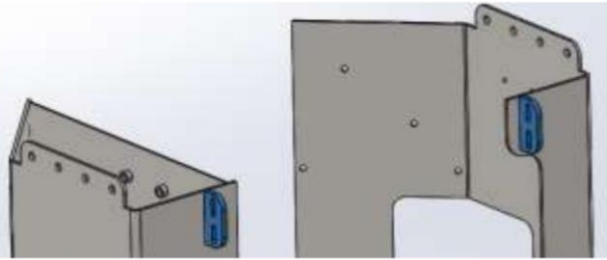

Tack the brackets to the casing and weld them; a waterproof weld inside the tank is needed to avoid any leaks.

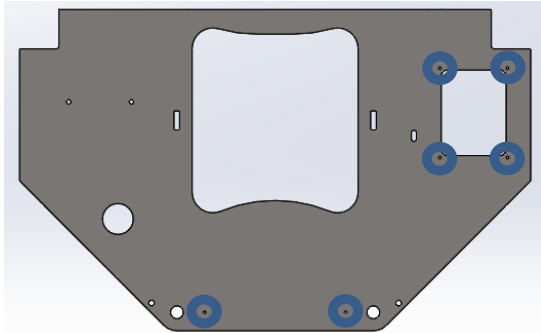

Before tacking the top plate of the turret, drill and tap the 6 M6 holes as shown here.

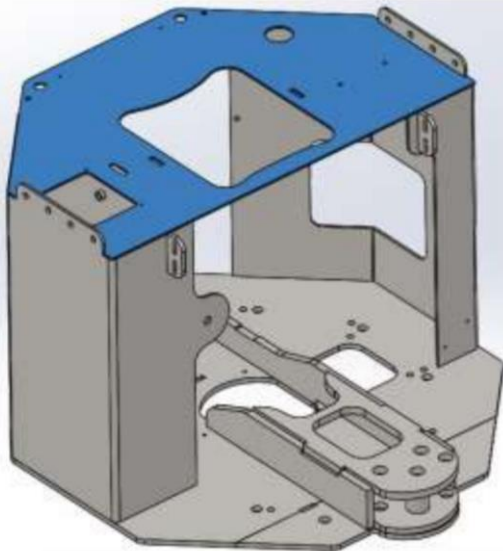

Tack the plate in place, be careful that all the edges are touching each other.

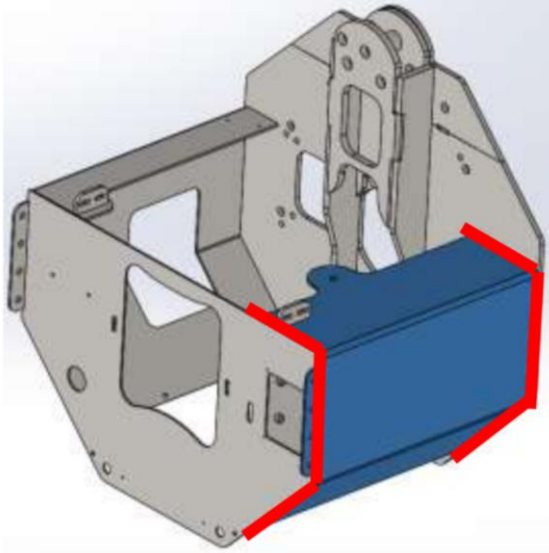

Flip the turret on its back to facilitate welding and do the outside edges of the tank.

Once the welds are finished, plug the tank holes and test the sealing with, if possible, at least 3 bar of pressure.

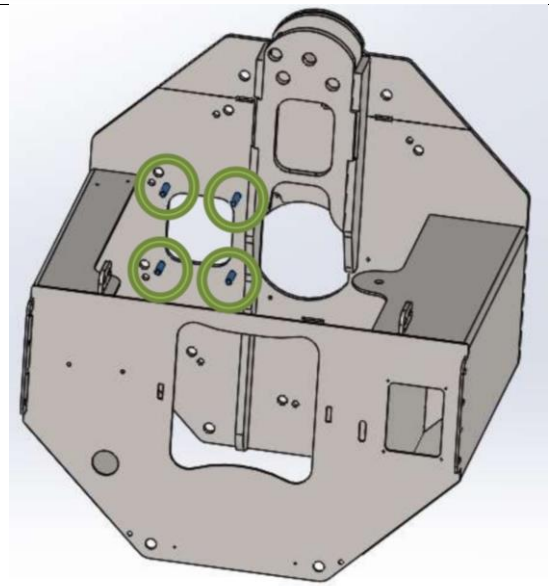

With the turret still on the side, screw in the 4 headless bolts m14x50 and strongly tack them from underneath the platform.

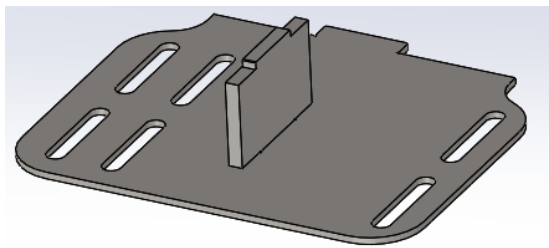

Weld the motor support plate's shim.

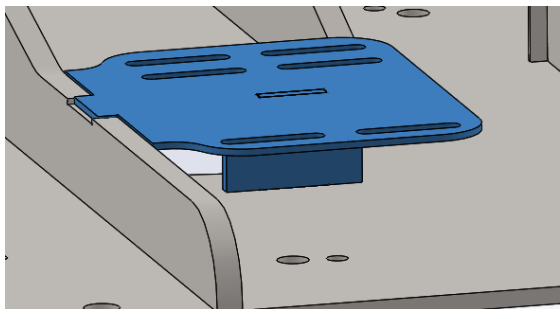

Tack the plate on the turret.

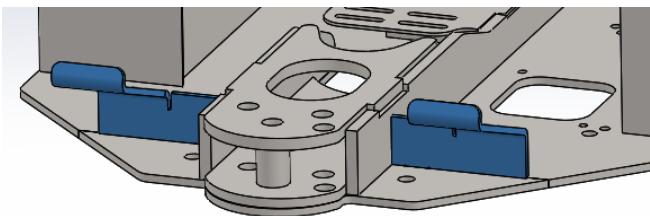

Tack the footrests on the turret.

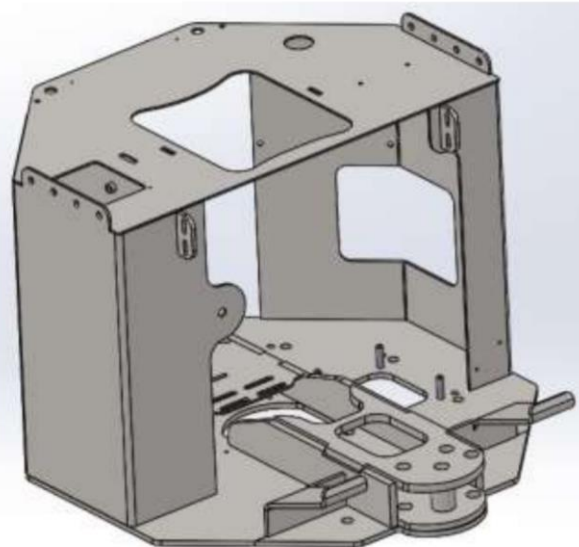

Weld everything else.

Be careful not to deform the structure while welding.

Slewing bracket

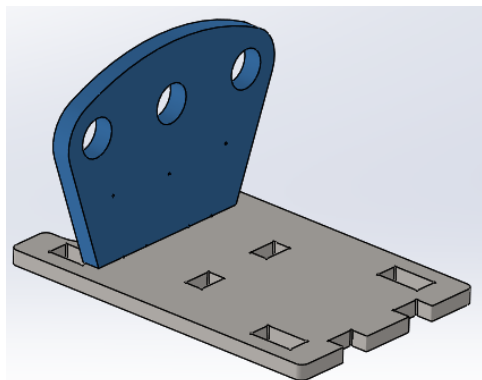

Tack the fist bracket square on the backplate.

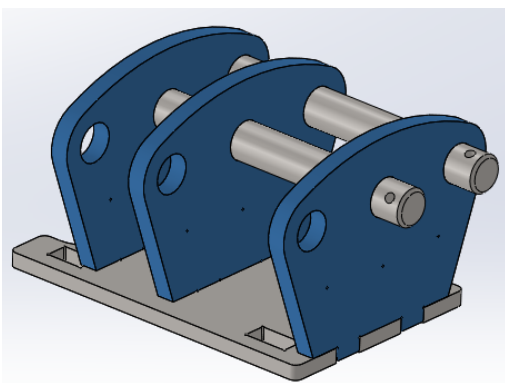

Tack the other 2 using a shaft to align them properly.

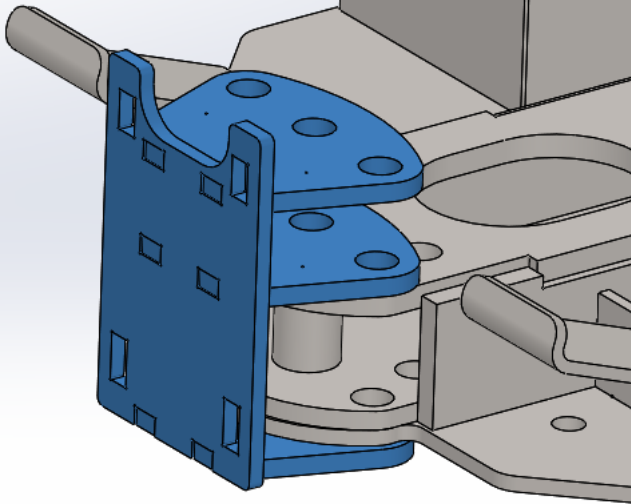

Check if the holes of the slewing brackets and the turret are aligned and the spacing is correct.

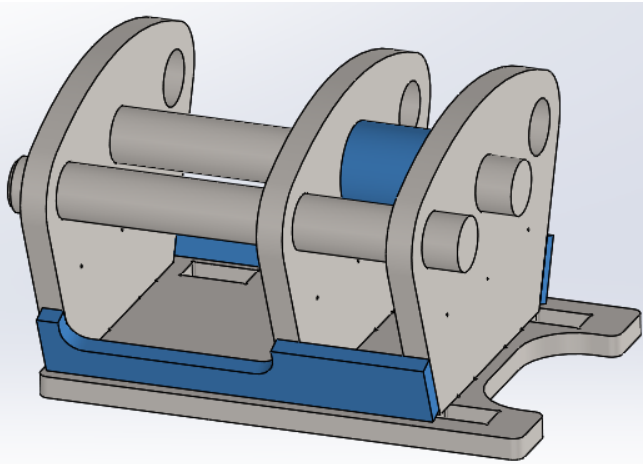

Tack the side reinforcement bracket and the $\varnothing 25$ lg 48 bushing.

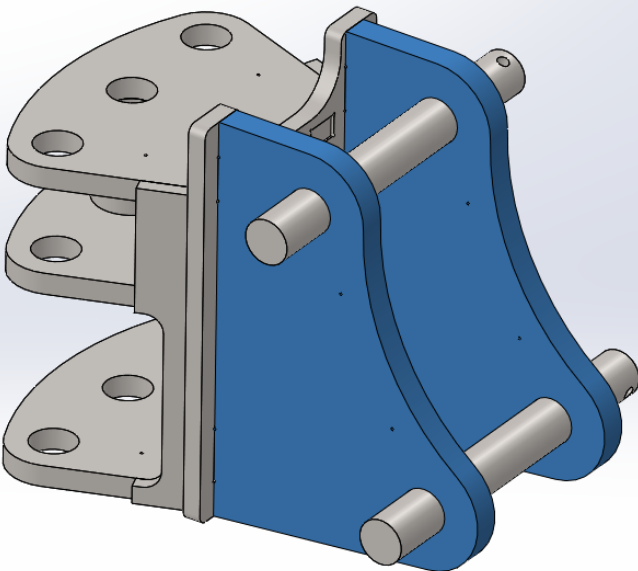

Tack the side plates and align them with shafts.

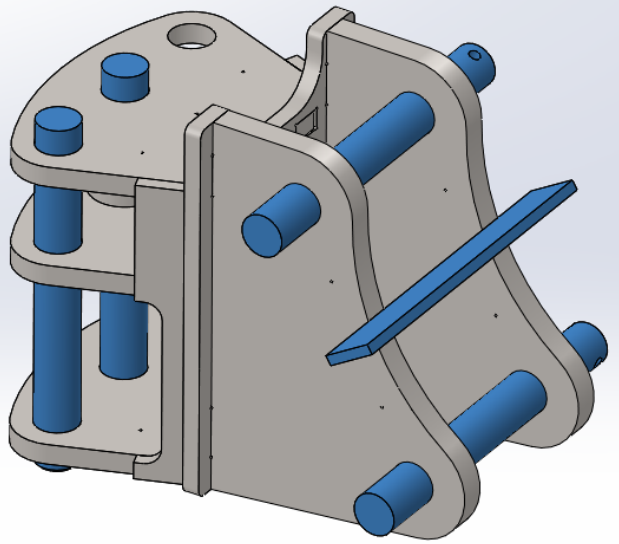

Place all the shafts and tack a metal piece to lock the spacing.

Weld the entire slewing bracket, be careful not to deform it while welding.

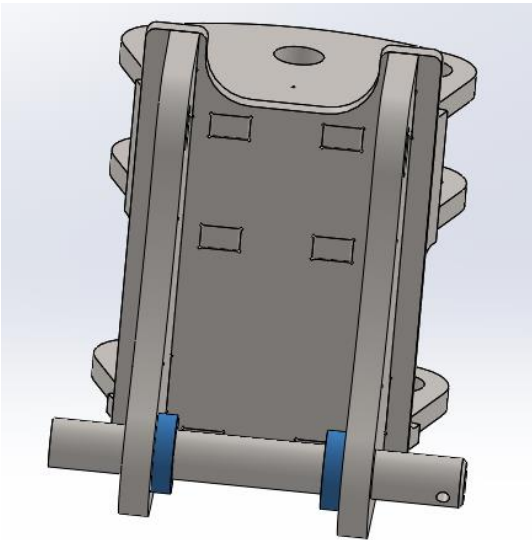

Weld 2 Ø25 lg 10 bushing inside the side plates.

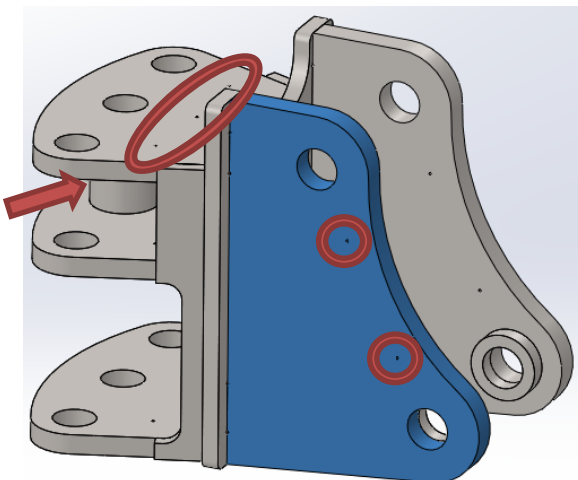

Drill and tap with M6 :

- 2 on the left side bracket
- 3 on the top bracket
- 1 for a grease fitting on the bushing

Boom (part 1)

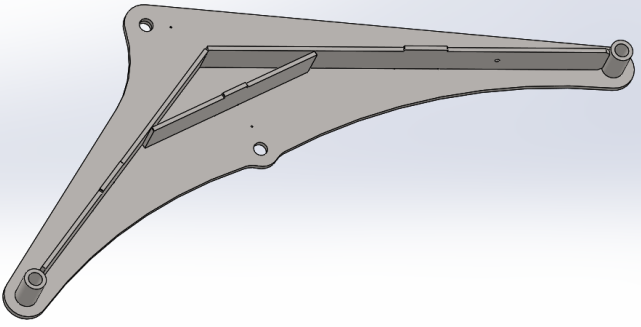
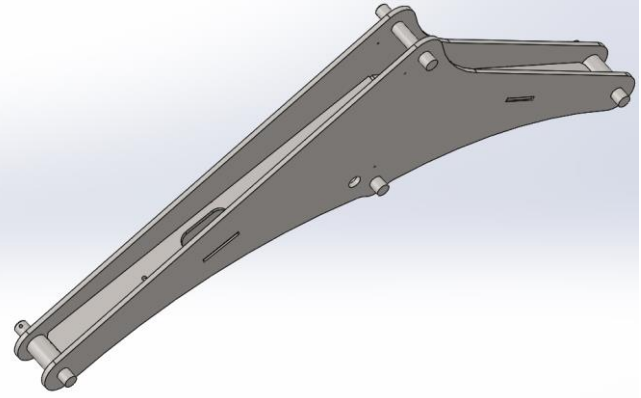
	<p>Tack the 3 reinforcement plates square in the mortices and a $\varnothing 25$ lg 72 bushing on each side.</p>
	<p>Place the other side and align the holes with shafts and tack them together.</p> <p>Do not weld completely it now</p>
<p>Tack the stick before the final welding</p>	

Arm/stick (part 1)

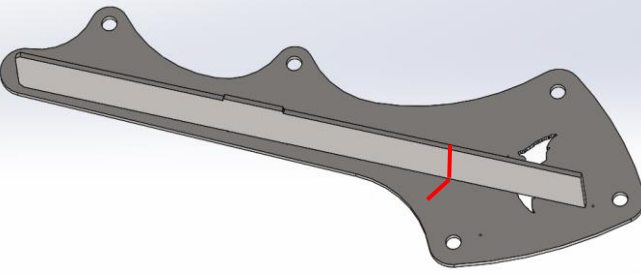
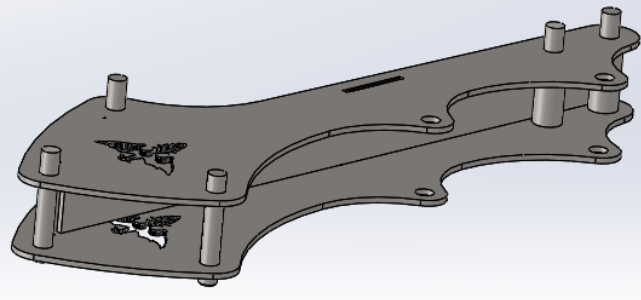
	<p>Tack the reinforcement plate on one side of the arm square in the mortice.</p>
	<p>Tack the second side with 2 $\varnothing 25$ lg 94 bushings aligned with shafts.</p>

Boom and arm (end)

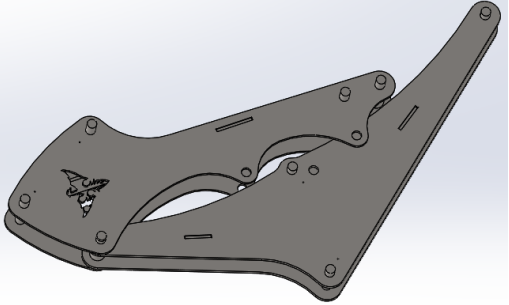
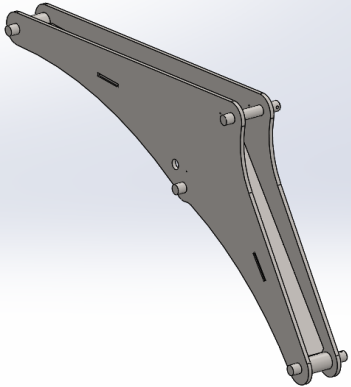
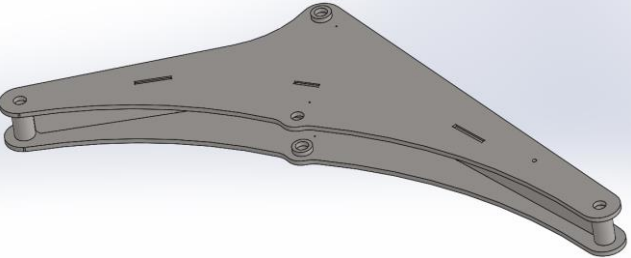
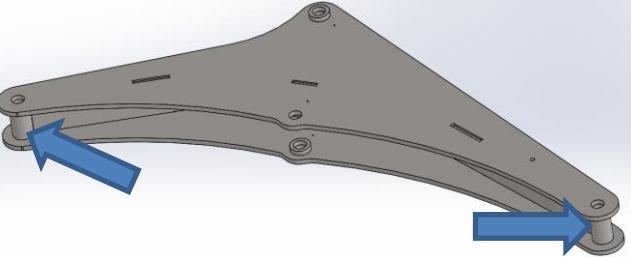
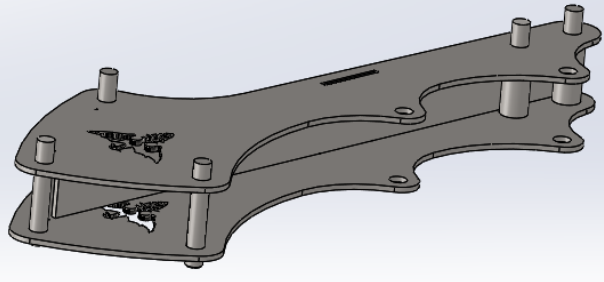
	<p>Fit them on the pivot point to check if there is not problems them tuck the boom in the arm to check for any deformation; if there is some, you need to arrange that while welding.</p>
	<p>Weld the boom, be careful not to deform it while welding.</p>
	<p>Weld the bushings on the boom:</p> <ul style="list-style-type: none">- 2 Ø25 lg 10 bushings inside the boom- 1 Ø25 lg 10 bushing on the top hole and a teardrop on the other face of the arm
	<p>Drill and tap with M6 both bushings for a grease fitting.</p> <p><u>Warning, do not drill where the cylinder will be otherwise the grease fitting won't be accessible.</u></p>
	<p>Weld the arm, be careful not to deform it while welding.</p>

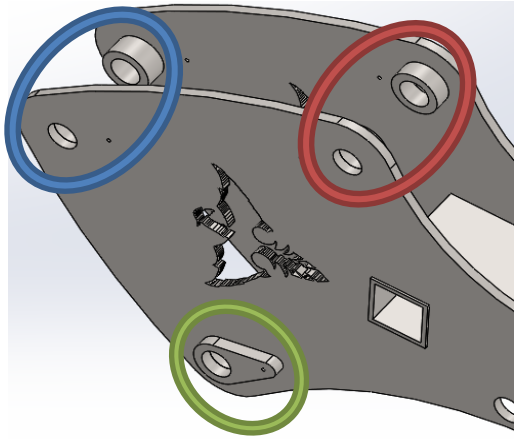

Weld the bushings on the arm :

Be careful to put the right bushing in the right place

- 2 Ø25 lg 15 bushings in the arm (red)
- 2 Ø25 lg 20 bushings in the arm (blue)
- 1 Ø25 ep 10 teardrop on the right side and a Ø25 lg 10 bushing on the left side (green)

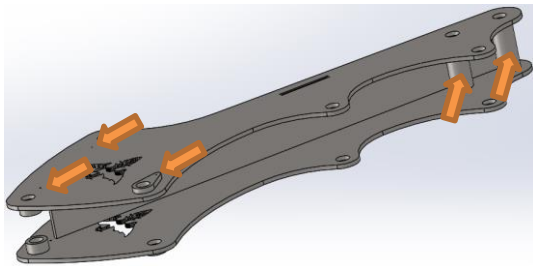

Drill and tap with M6 the arm to lock the teardrop and place grease fittings

Warning, do not drill where the cylinder will be otherwise the grease fitting won't be accessible.

Arm bracket

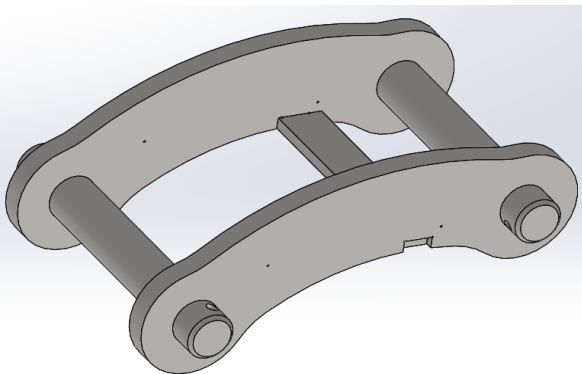

Place a shaft in each hole.

Before welding, check than all side are coplanar, they must all touch a straight surface, then weld it.

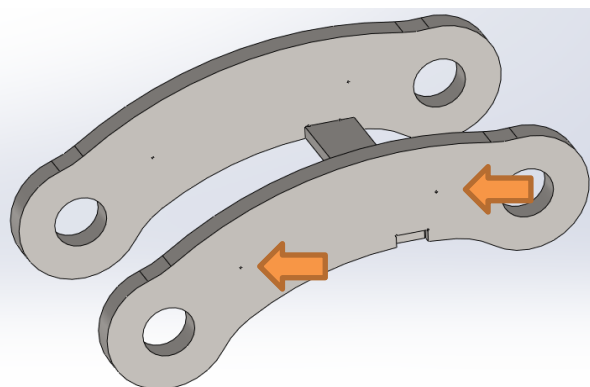

Drill and tap with M6 to lock the teardrop.

Bucket bracket

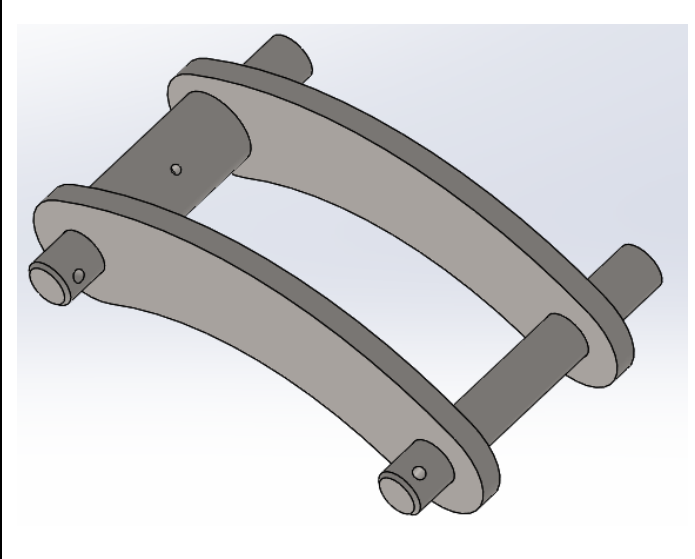
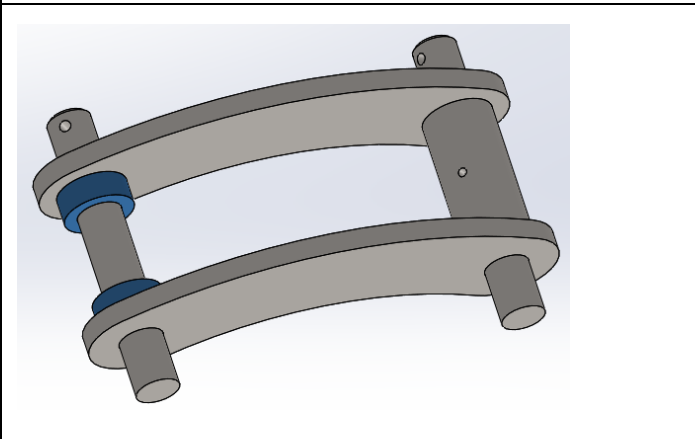
	<p>Place a shaft in each hole and a $\varnothing 25$ lg 84 bushing on one side.</p> <p>Before welding, check than all side are coplanar, they must all touch a straight surface, then weld it.</p>
	<p>Weld 2 $\varnothing 25$ lg 15 bushing on each side and align them with a shaft.</p>

Seat plate

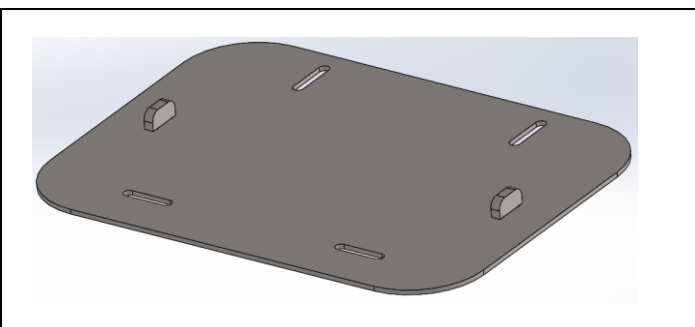
	<p>Weld the bracket on the plate.</p> <p>Do dot weld under the plate do that it can fit tightly against the turret.</p> <p>Grind the excess weld so there is no hindrance when installing the seat.</p>
--	---

Track gears x2

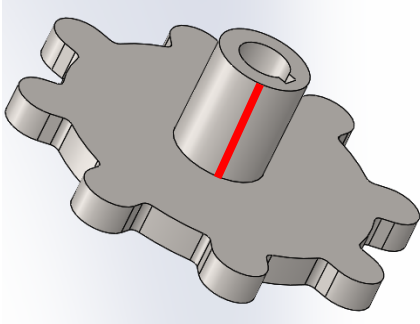
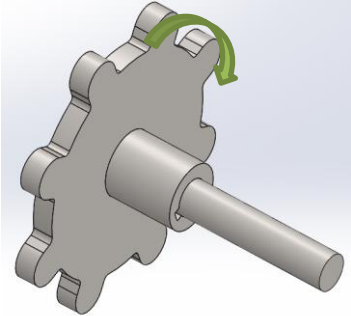
	<p>Tack the retaining bushing at the center of the gear.</p> <p>The position of the keypath does not matter, the 2 hydraulic motor are completely independent.</p>
	<p>Place a $\varnothing 25$ shaft in the bushing.</p> <p>Turn the gear to see if it is not curved, if not, weld the track gear.</p>

Rollbar

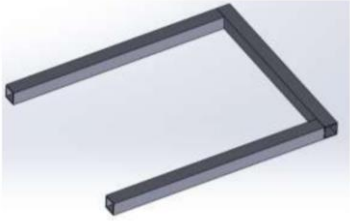
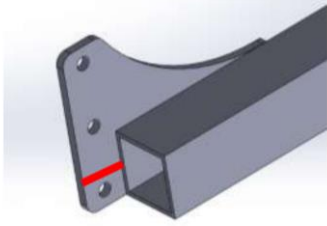
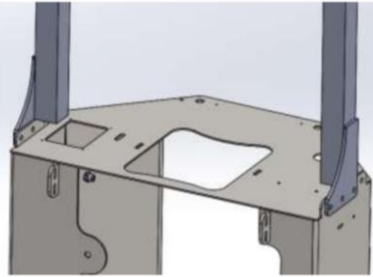
	<p>Tack the 2 sides of 980 mm on the 835 mm top bar.</p> <p>Be careful to keep the 2 sides perfectly parallels.</p>
	<p>Weld the 2 fixations plates on the outside of the tubes.</p> <p>The fixation plate is welded 40 mm after the end of the tube (distance shown in red)</p>
	<p>Check that the rollbar fit on the turret fixations without problems. Once it fits properly, lock the rollbar in place and finish the welding.</p>

Attachments:

Ripper

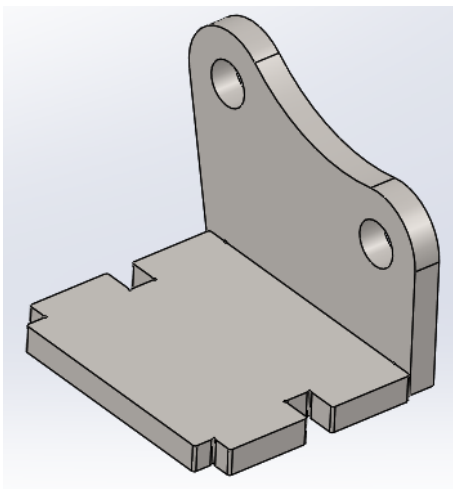

Tack the first side square on the backplate.

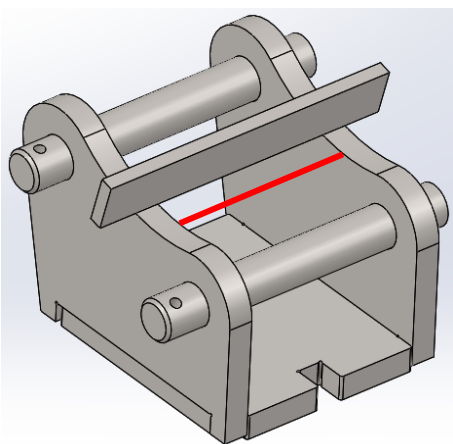

Tack the second side by aligning it with 2 $\varnothing 25$ shafts.

Tack a piece of metal to maintain the spacing at 112 mm between the two sides.

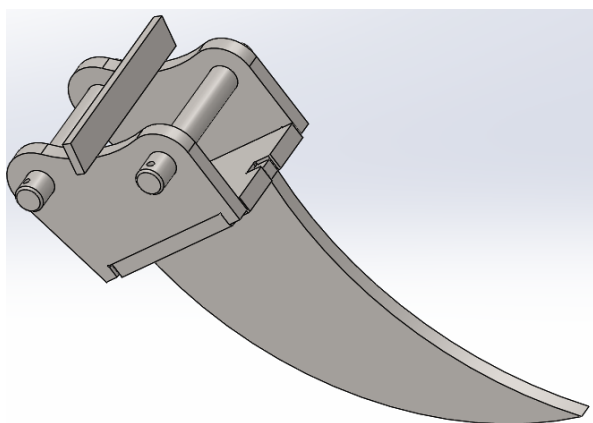

Tack the ripper with the tip on the same side as the small side of the side plates.

Weld the ripper and take the metal spacer off once cooled.

Bucket (general assembly)

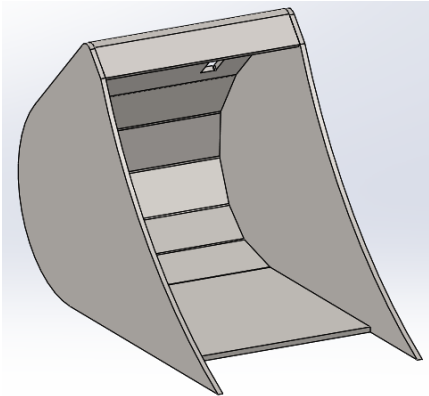

Tack the side of the bucket.

Do not hesitate to bend the backplate to have a better fit with the sides.

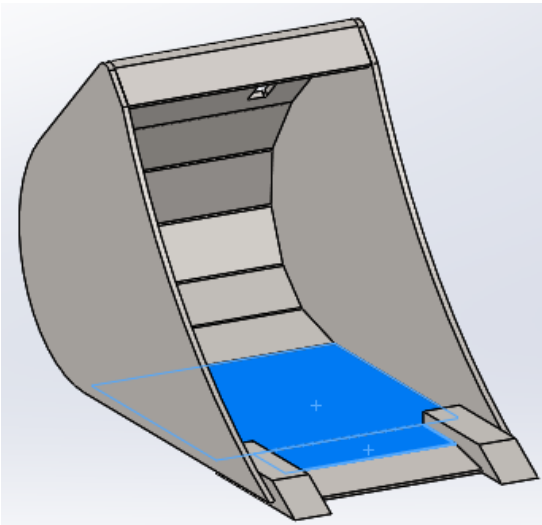

Place the blade and the teeth, align the top of the plate with the interior of the bucket.

The teeth can be placed with several different positions, it is possible to skip this step.

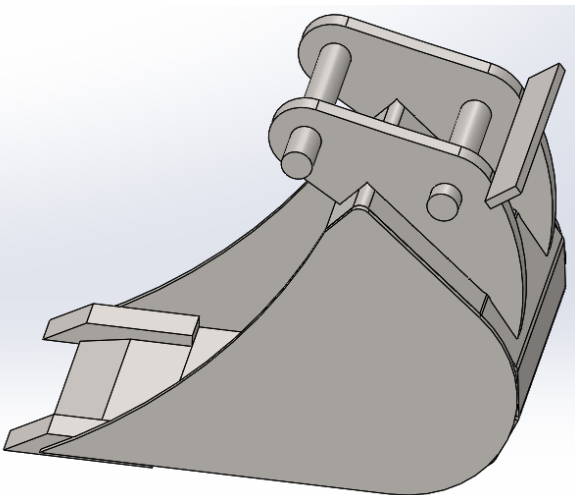

Place the brackets square in the mortices, place two shafts and tack a piece of metal to maintain a spacing of 112 mm between the brackets.

Weld the bucket and take off the metal spacer once cooled.

Front loading bucket

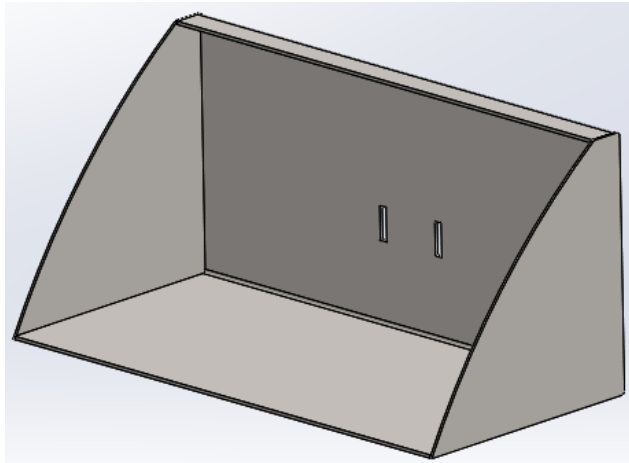

Tack the sides to the bucket. Do not hesitate to bend the backplate to have a better fit with the sides.

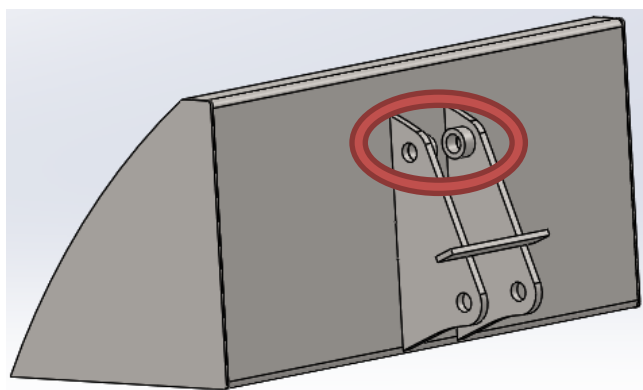

Place the brackets on the mortices then align the 2 $\varnothing 25$ lg 20 (red) bushings with 2 shafts and a metal spacer.

Weld the bucket and take off the metal spacer once cooled.

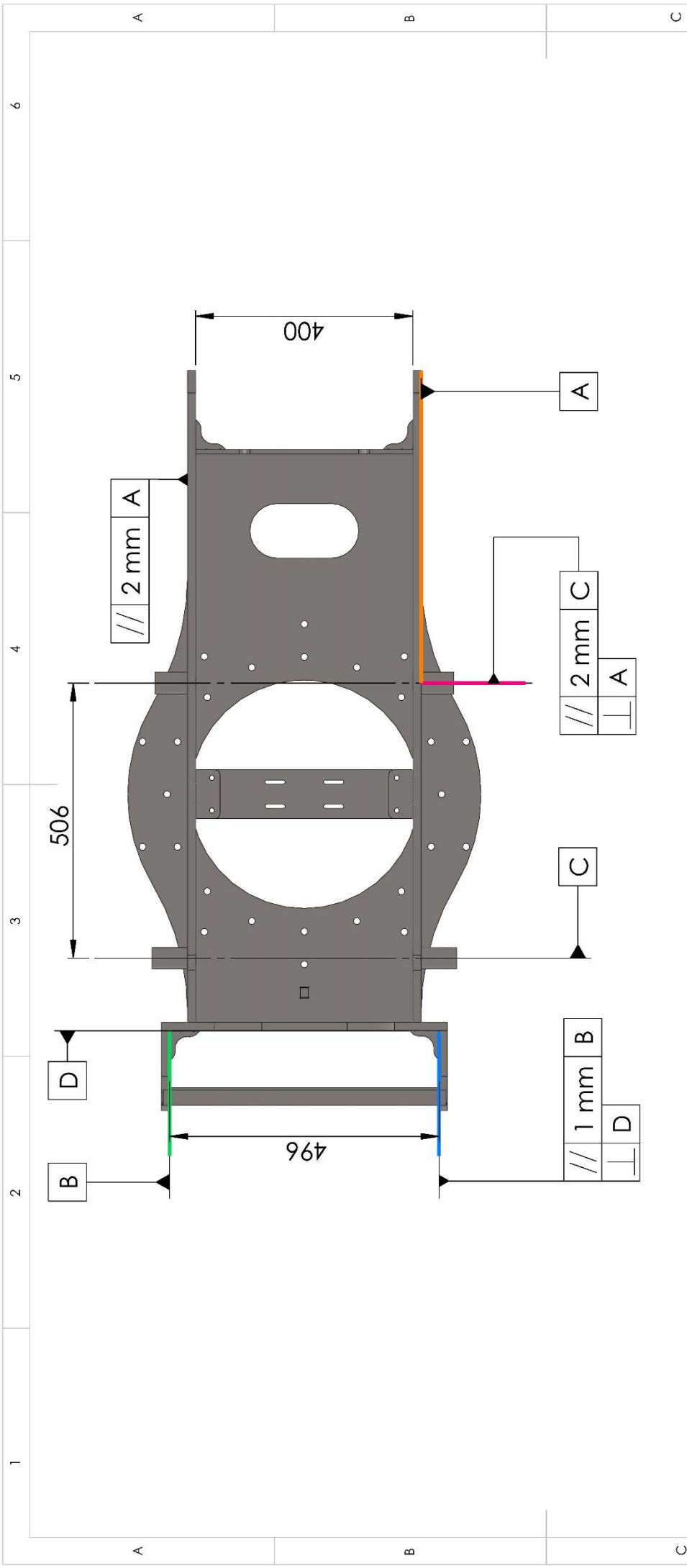

Tolérance générale de soudure + ou - 1 mm

/// 1 mm B

Parallélisme de la surface de référence (Bleu) par rapport à la surface B (Vert) avec un décalage maximum de 1 mm en plus ou en moins par rapport à la cote de 496mm.

⊥ 1 mm A

Perpendicularité de l'axe de référence (Rose) par rapport à la surface A (Orange)

Date de dernière mise à jour: jeudi 15 novembre 2018 11:21:19	No. DE PLAN A4
Matière: Acier	Explication cotation
Cotes en mm	SAS HHO - France
1	2
3	3
FEUILLE 1 SUR 1	

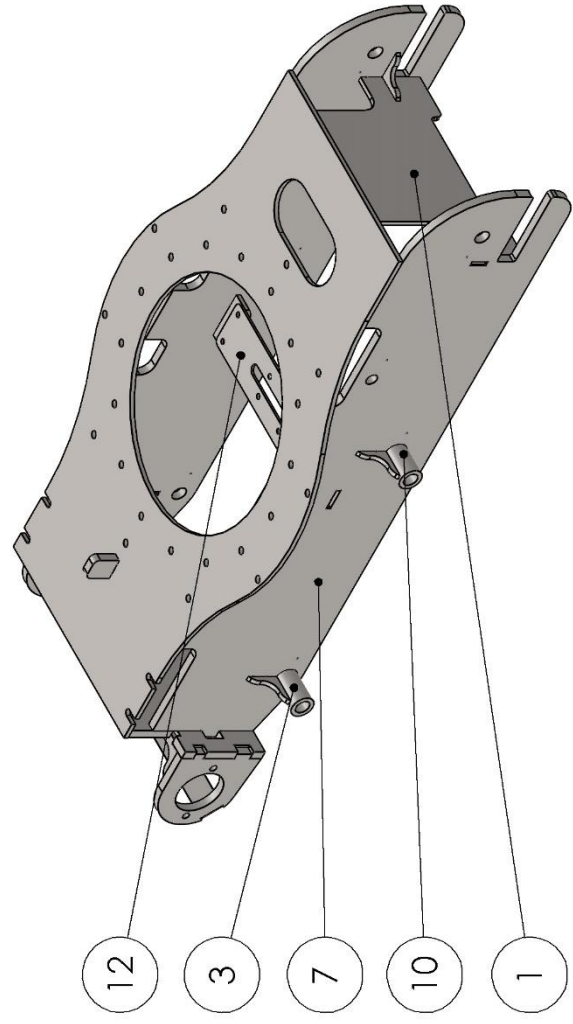
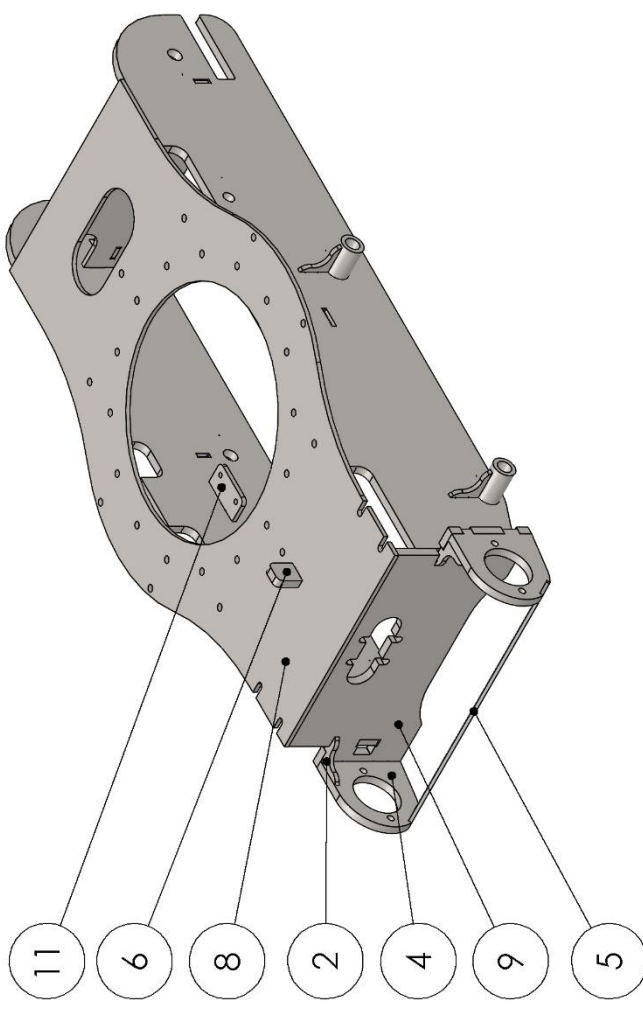

No. ARTICLE	NUMERO DE PIECE	QTE
1	LA-1306-8-A	1
2	LA-1309-8-A	8
3	BA-25.25 lg 65	2
4	LA-1311-15-A	2
5	LA-1312-6-A	1
6	LA-1310-15-A	1
7	LA-1308-15-C	2
8	LA-1305-8-C	1
9	LA-1307-15-B	1
10	BA-25.25 lg 60	2
11	LA-1265-8-A	2
12	LA-1266-4-C	1

Poids: 116 kgs

Date de dernière mise à jour: jeudi 21 novembre 2019 08:23:30

Matière: Acier

No. DE PLAN: PH400 - Nomenclature Chassis Bas A4

Cotes en mm

SAS HHO - France

FEUILLE 1 SUR 1

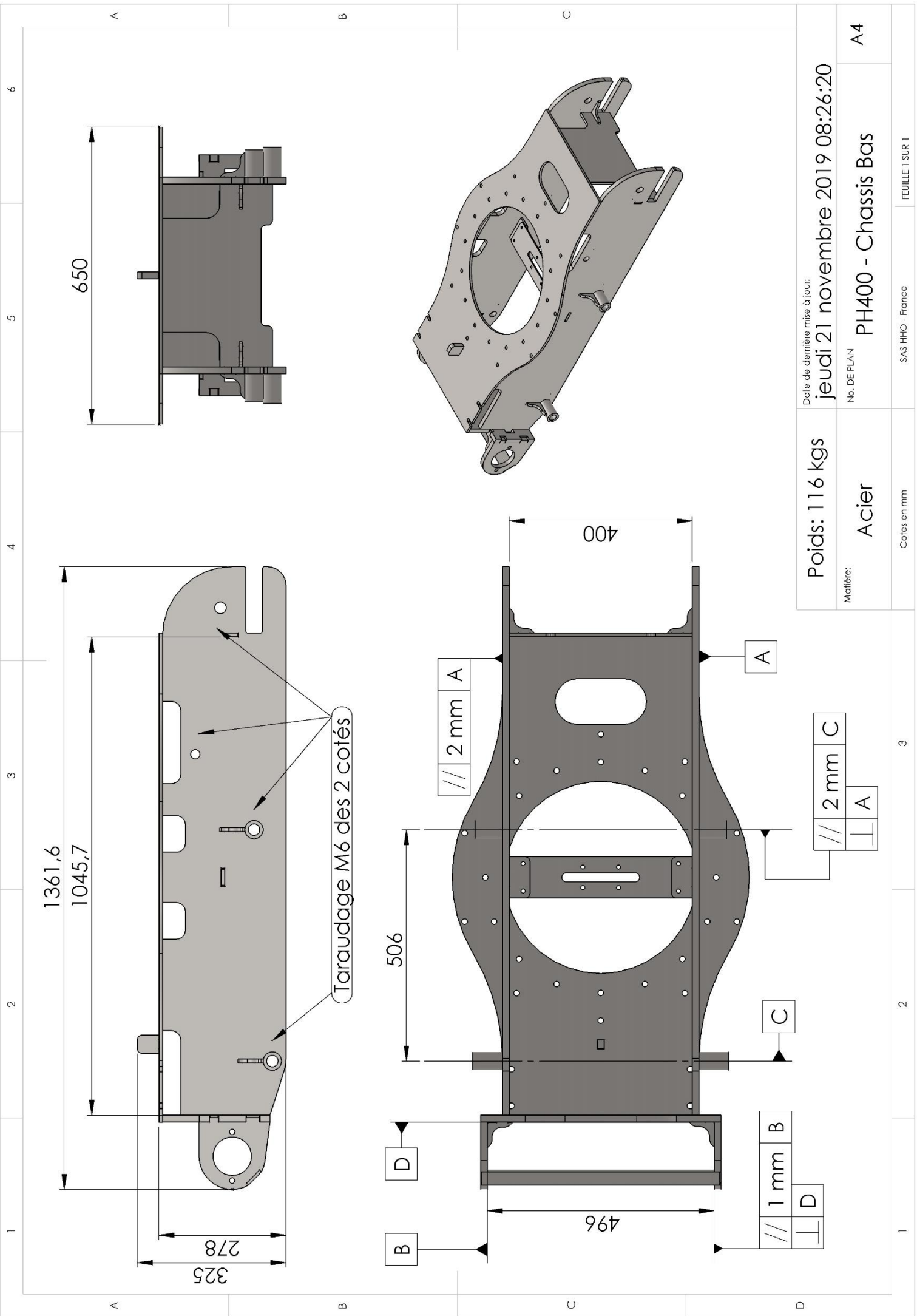

Poids: 116 kgs	Date de dernière mise à jour: jeudi 21 novembre 2019 08:26:20	
	Matière: Acier	No. DE PLAN PH400 - Chassis Bas
Cotes en mm		FEUILLE 1 SUR 1

A4

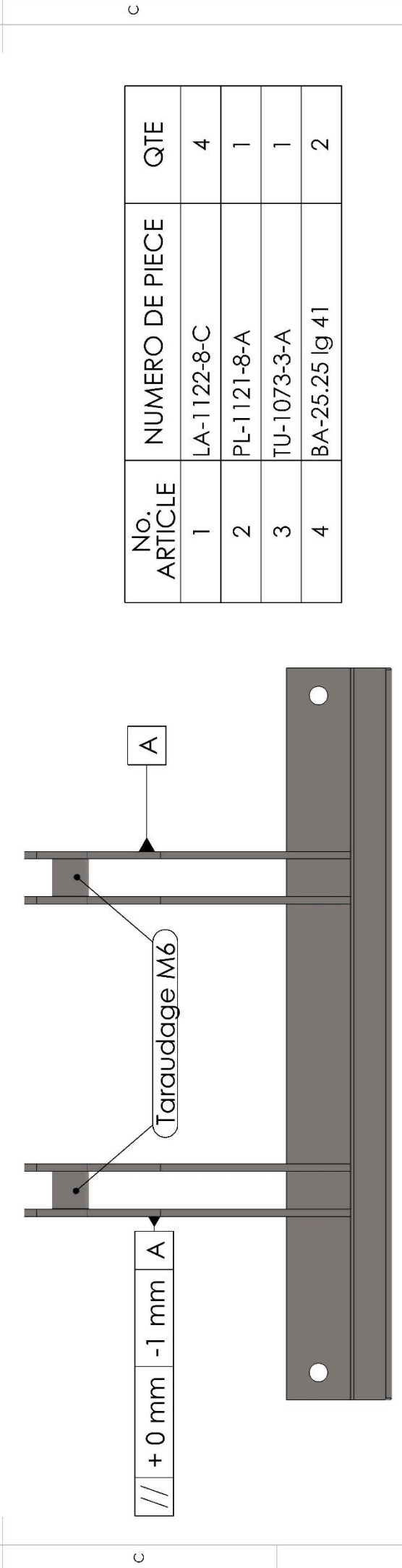
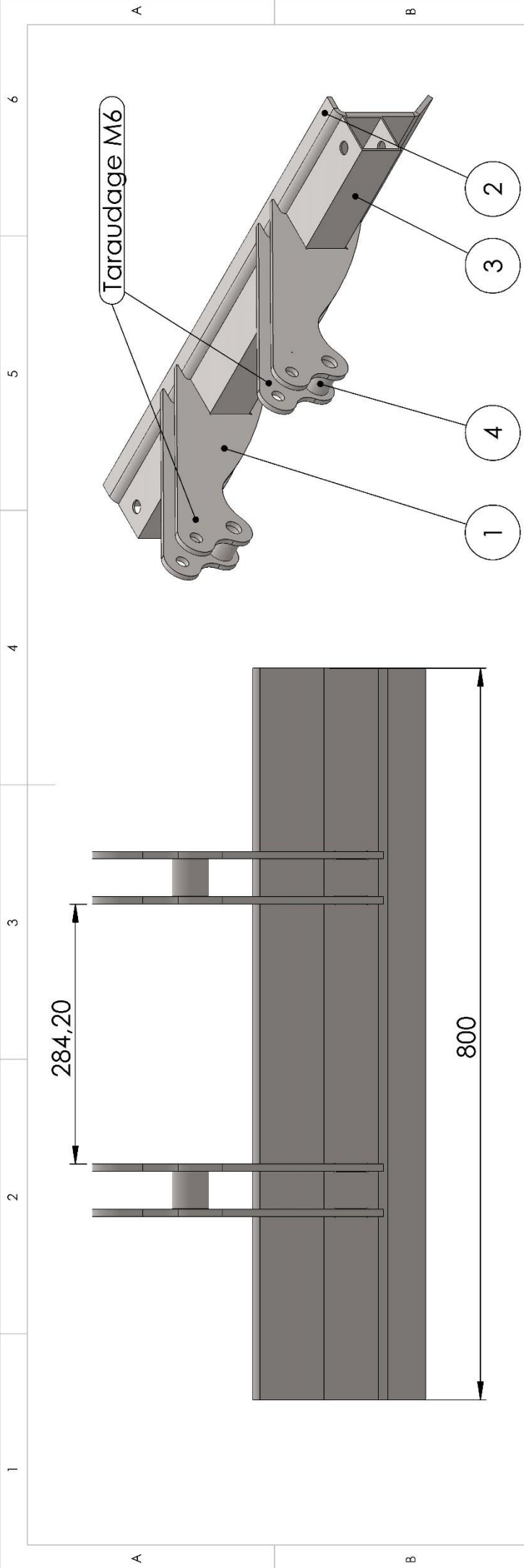

No. ARTICLE	NUMERO DE PIECE	QTE
1	LA-1122-8-C	4
2	PL-1121-8-A	1
3	TU-1073-3-A	1
4	BA-25.25 lg 41	2

Poids: 116 kgs

Date de dernière mise à jour: **jeudi 15 novembre 2018 14:29:16**

Matériau: **Acier**

No. DE PLAN: **PH400 - lame Stabilisatrice**

Matière: **Acier**

Cotes en mm

SAS HHO - France

FEUILLE 1 SUR 1

1 2 3

A4

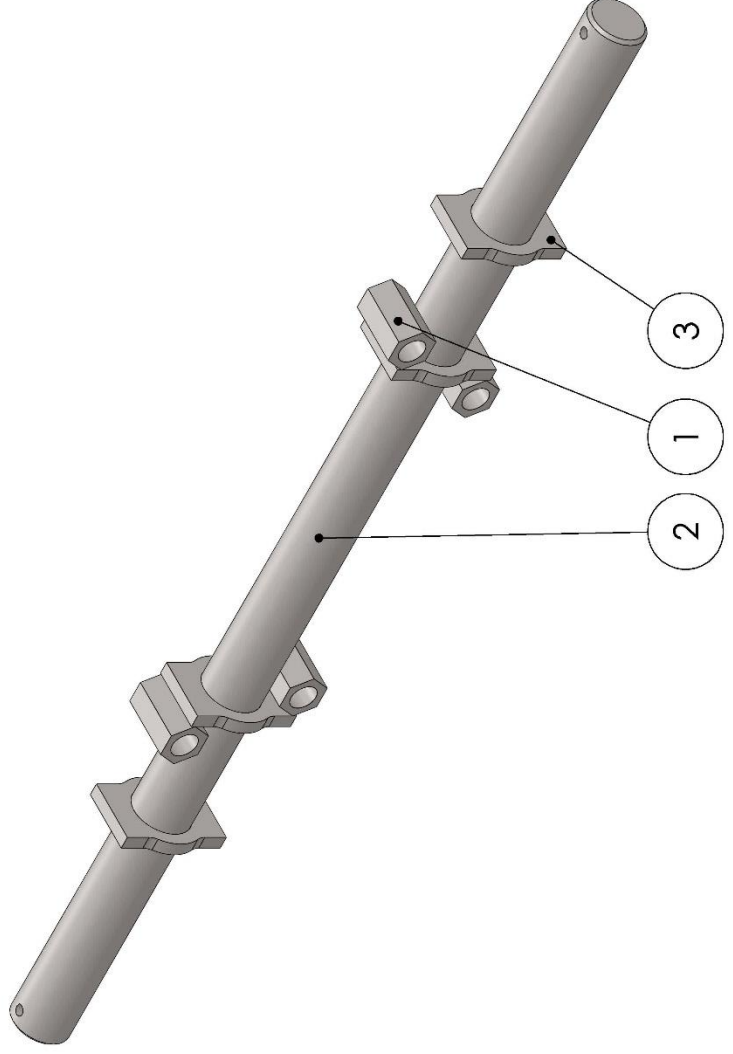
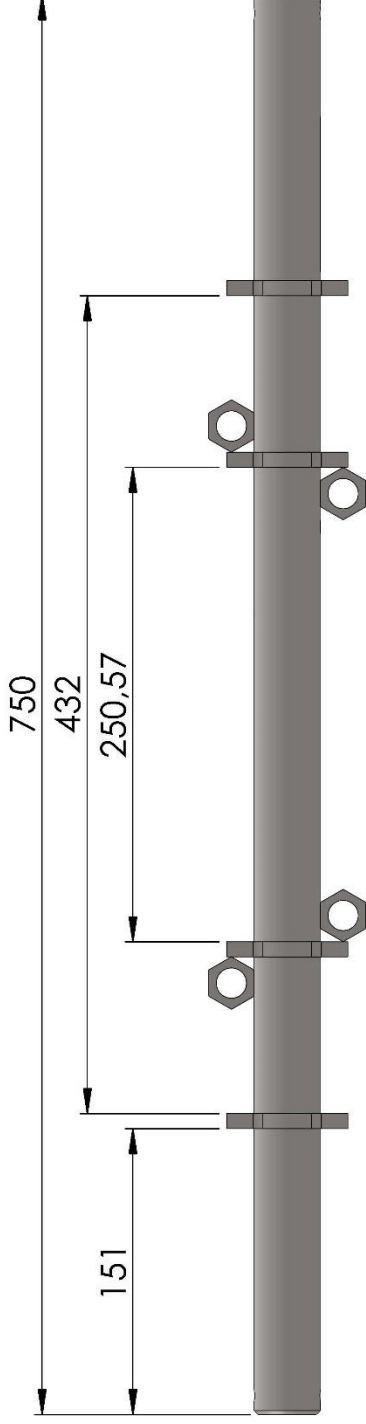

NO. ARTICLE	NUMERO DE PIECE	QTE
1	Ecrou M16 long	4
2	A-35 Ig 720-2P	1
3	LA-1342-8-A	4

Poids: 7.5 kgs

Date de dernière mise à jour:

lundi 26 novembre 2018 09:27:55

Matériau:

Acier

No. DE PLAN

PH400 - Tendeur

A4

Cotes en mm

SAS IHO - France

FEUILLE 1 SUR 1

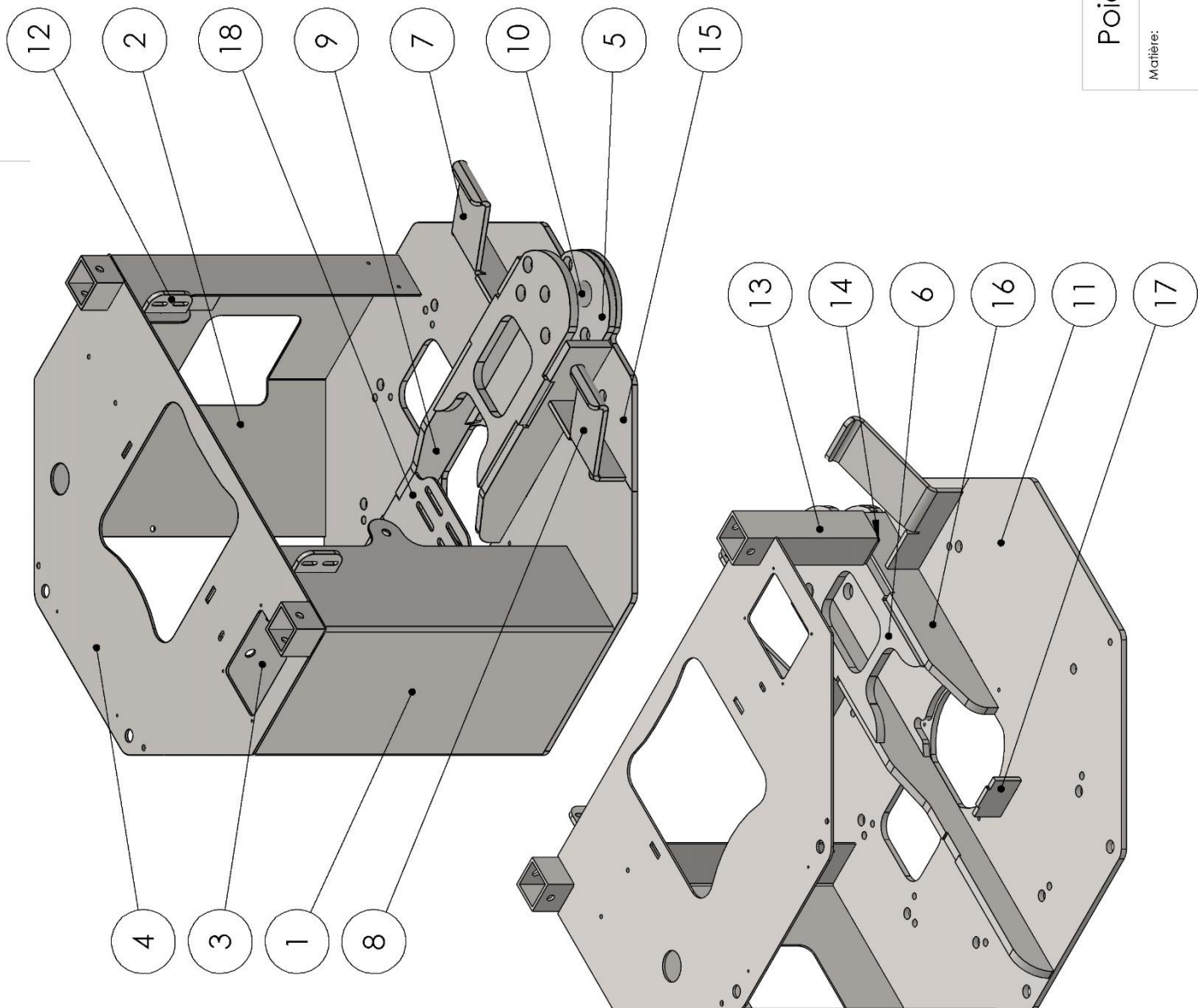

NO. ARTICLE	NUMERO DE PIECE	QTE
1	PL-1330-3-A	1
2	PL-1329-3-C	1
3	LA-1331-3-A	1
4	LA-1328-4-B	1
5	LA-1318-12-A	1
6	LA-1319-15-B	1
7	PL-1320-8-A	1
8	PL-1321-8-A	1
9	LA-1316-15-A	1
10	BA-25.25 lg 60	1
11	LA-1315-10-B	1
12	LA-1325-8-B	2
13	TU-1272-5-B	2
14	LA-1271-4-A	1
15	LA-1314-10-A	1
16	LA-1317-15-A	1
17	LA-1326-8-A	1
18	LA-1327-4-A	1

Poids: 115 kgs

Date de dernière mise à jour: jeudi 21 novembre 2019 08:29:08

Matière: Acier

No. DE PLAN PH400 - Chassis Haut - nomenclature A4

Cotes en mm

SAS IHIO - France

FEUILLE 1 SUR 1

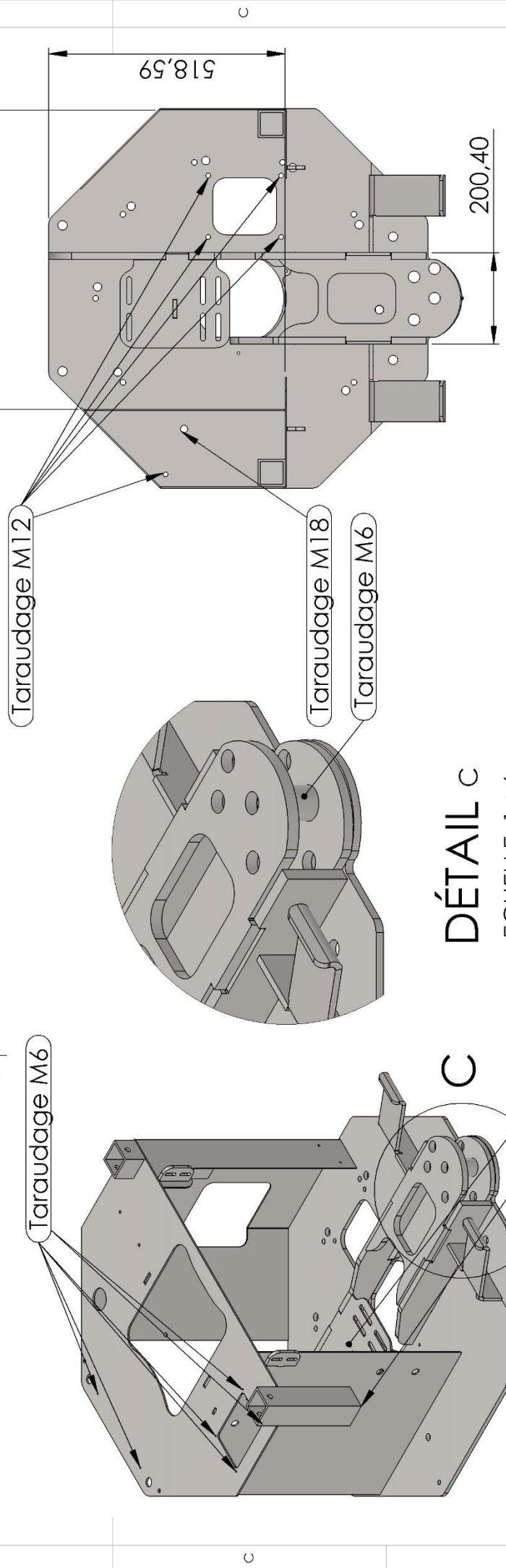
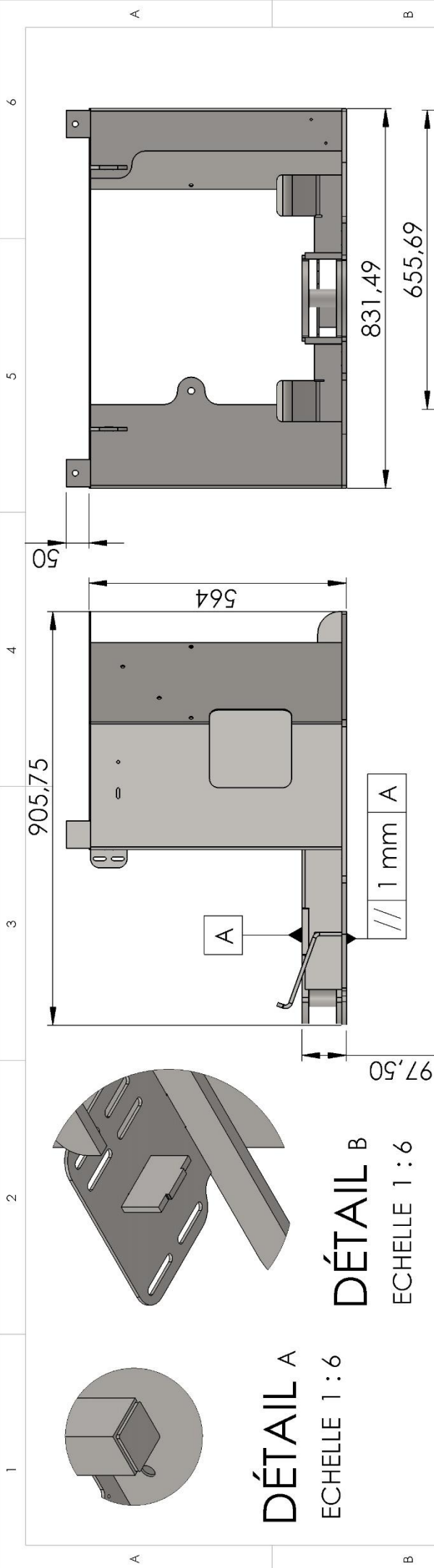

Poids: 115 kgs Matière: Acier	Date de dernière mise à jour: jeudi 21 novembre 2019 08:32:51	No. DE PLAN PH400 - Chassis Haut
Coles en mm SAS HHO - France FEUILLE 1 SUR 1		

DÉTAIL C
 ECHELLE 1 : 6

DÉTAIL A
 ECHELLE 1 : 6

DÉTAIL B
 ECHELLE 1 : 6

Détail B
 Détail A

1 2 3 4 5 6

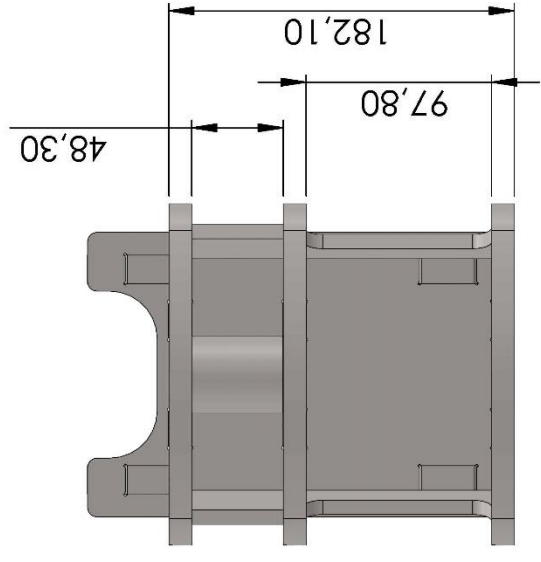
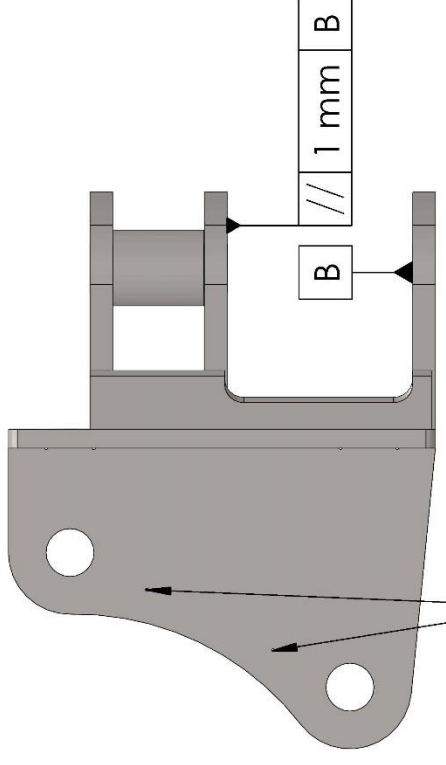
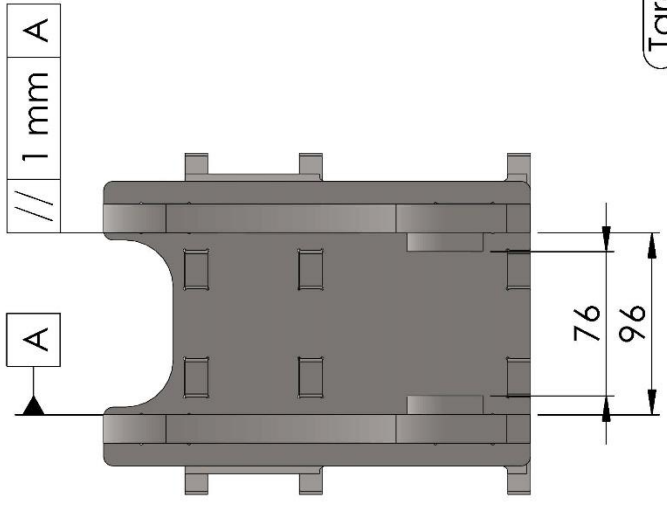

Taraudage M6

No. ARTICLE	NUMERO DE PIECE	QTE
1	LA-1340-10-A	1
2	LA-1338-15-A	2
3	LA-1339-12-A	3
4	LA-1341-8-A	2
5	BA-25.25 lg 48	1
6	BA-25.25 lg 10	2

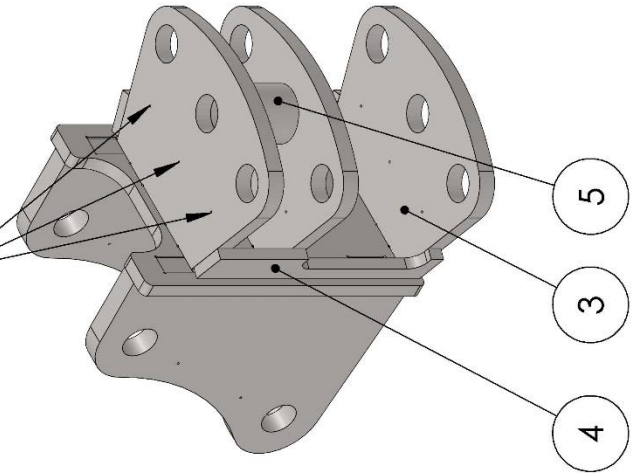
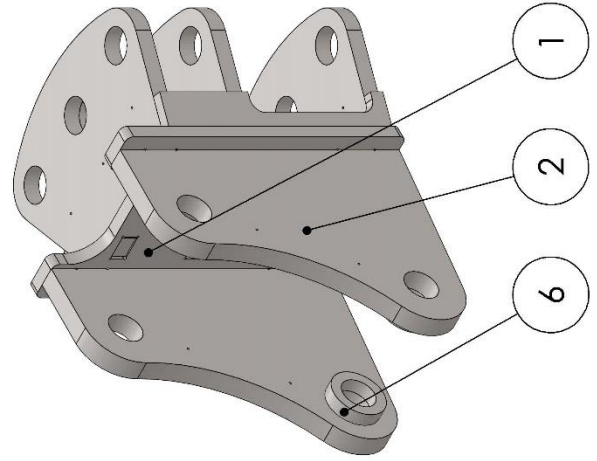

Poids: 13 kgs

Date de dernière mise à jour:

lundi 26 novembre 2018 10:27:11

Matière:

Acier

No. DE PLAN

PH400 - Noix

A4

Cotes en mm

SAS HHO - France

FEUILLE 1 SUR 1

A

B

C

D

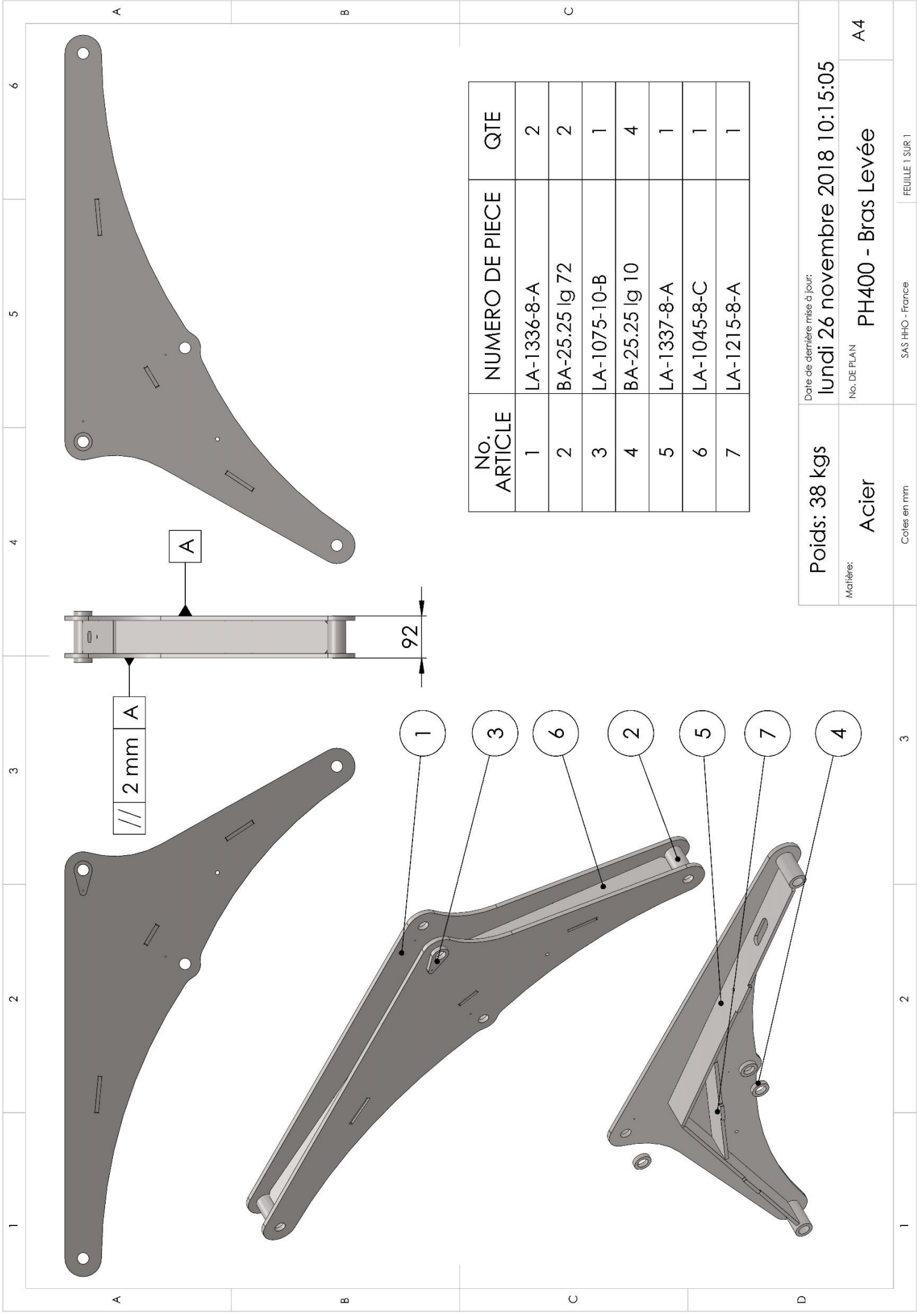

NO. ARTICLE	NUMERO DE PIECE	QTE
1	LA-1336-8-A	2
2	BA-25.25 lg 72	2
3	LA-1075-10-B	1
4	BA-25.25 lg 10	4
5	LA-1337-8-A	1
6	LA-1045-8-C	1
7	LA-1215-8-A	1

Poids: 38 kgs

Date de dernière mise à jour:

lundi 26 novembre 2018 10:15:05

Matière:

Acier

No. DE PLAN

PH400 - Bras Levée

A4

Cotes en mm

SAS HHO - France

FEUILLE 1 SUR 1

3

2

1

1 2 3 4 5 6

A B C

// 2 mm A

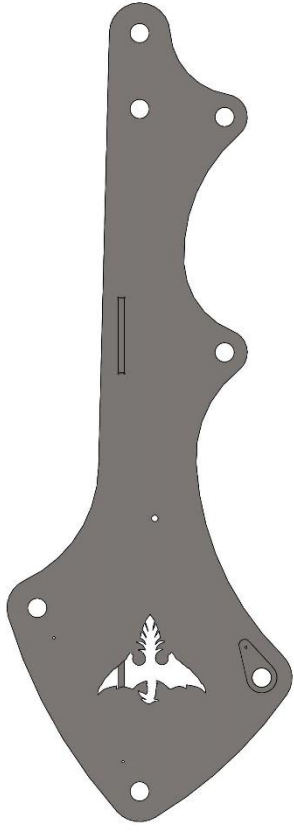
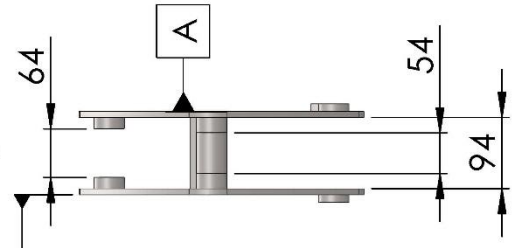
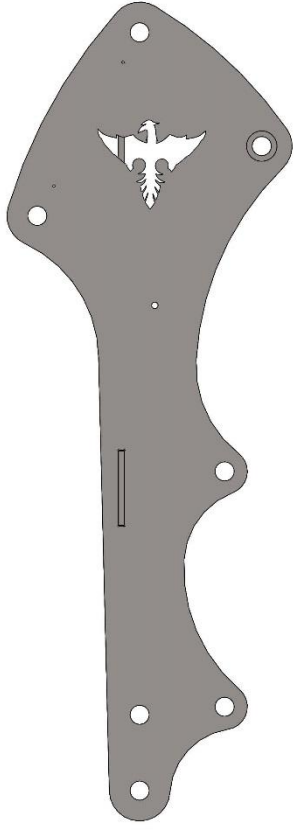

No. ARTICLE	NUMERO DE PIECE	QTE
1	LA-1335-8-A	2
2	BA-25.25-94	2
3	BA-25.25 lg 15	2
4	BA-25.25 lg 20	2
5	pBA-25.25 lg 10	1
6	LA-1075-10-B	1
7	LA-1046-8-C	1

Poids: 9 kgs

Date de dernière mise à jour:

Lundi 26 novembre 2018 10:06:33

Matériau:

Acier

No. DE PLAN

PH400 - Bras Balancier

A4

Cotes en mm

SAS HHO - France

FEUILLE 1 SUR 1

1 2 3

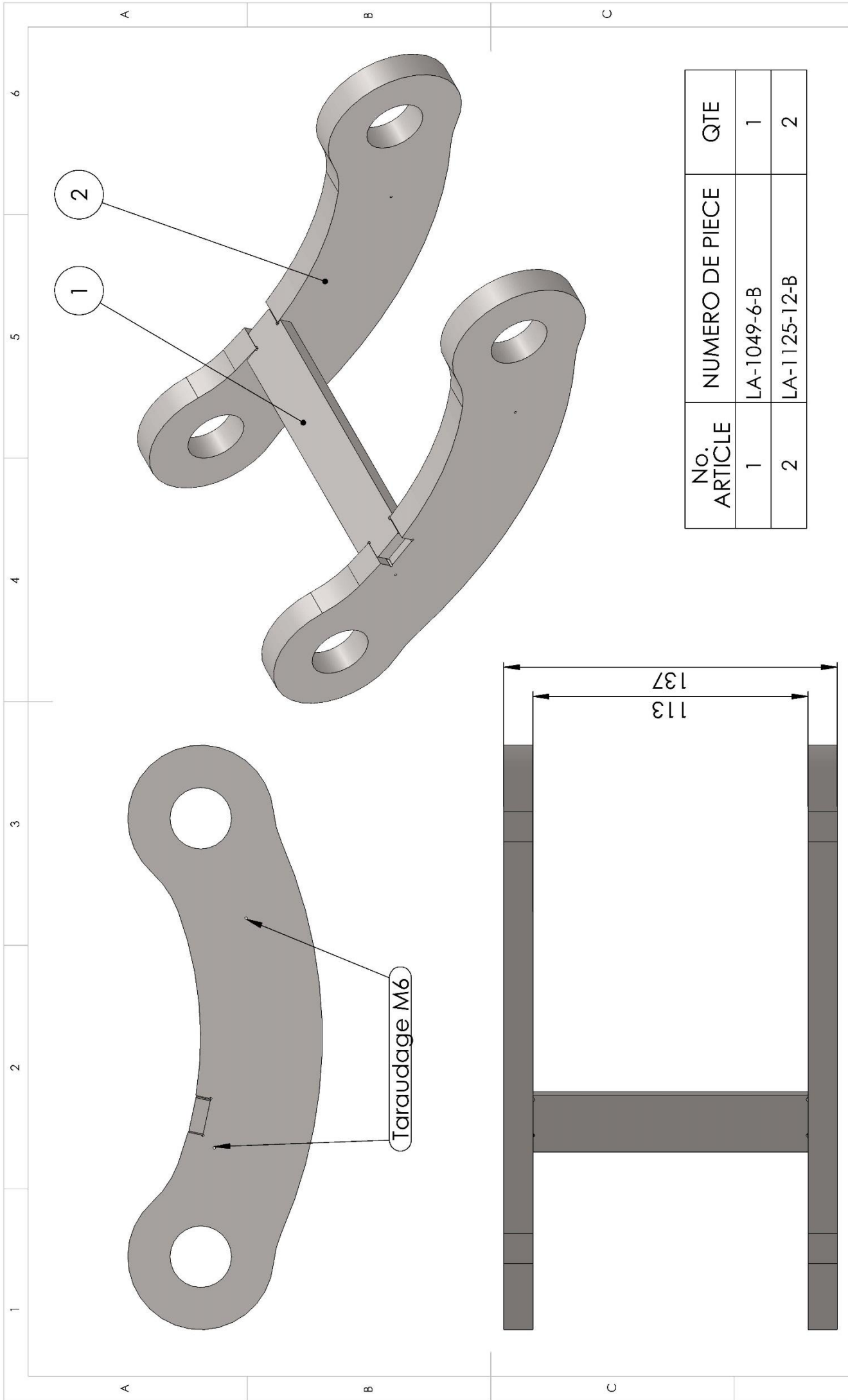

No. ARTICLE	NUMERO DE PIECE	QTE
1	LA-1049-6-B	1
2	LA-1125-12-B	2

Poids: 2.4 kgs Matière: Acier	Date de dernière mise à jour: lundi 26 novembre 2018 09:52:33	
	No. DE PLAN PH400 - Renvoi Bras	A4
Cotes en mm		SAS HHO - France

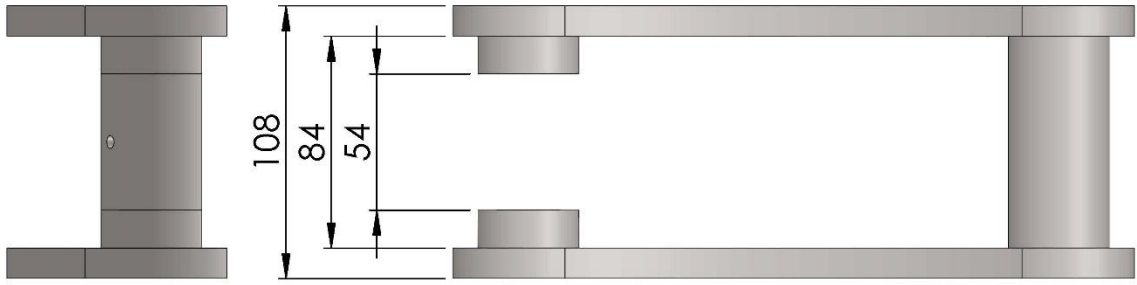

Taroudage M6

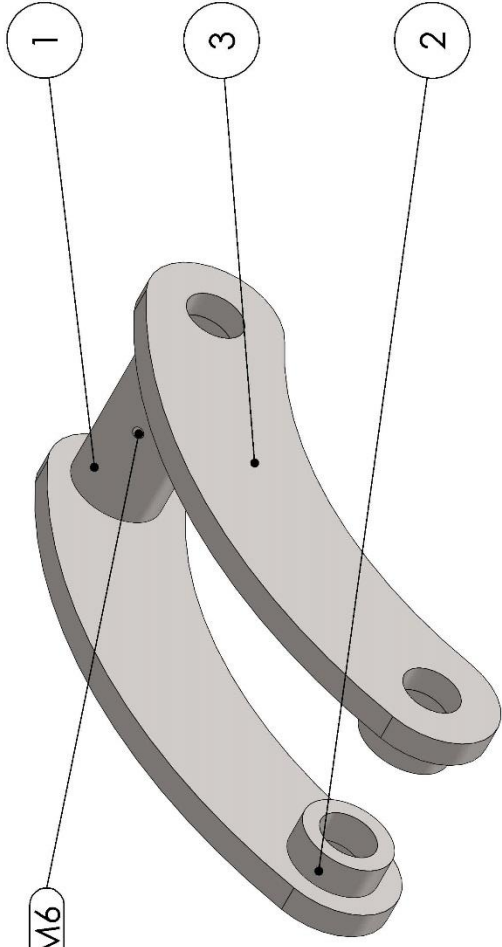

NO. ARTICLE	NUMERO DE PIECE	QTE
1	BA-25.25 lg 84	1
2	BA-25.25 lg 15	2
3	LA-1334-12-A	2

Poids: 3.9 kgs

Date de dernière mise à jour:

lundi 26 novembre 2018 09:48:34

Matériau:

Acier

No. DE PLAN

PH400 - Renvoi godet

A4

Cotes en mm

SAS IHO - France

FEUILLE 1 SUR 1

3

2

1

1 2 3 4 5 6

A A

B B

C C

D D

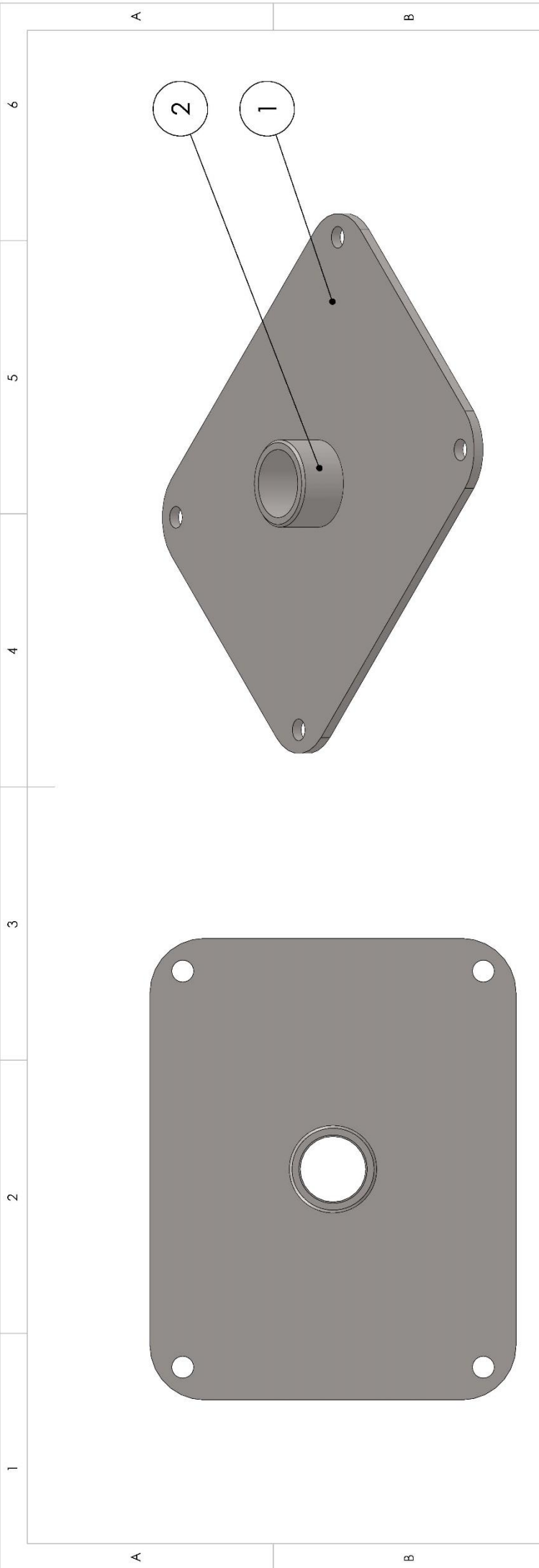

No. ARTICLE	NUMERO DE PIECE	QTE
1	LA-1060-4-C	1
2	Bossage M22_-	1

Poids: 1 kg Matière: Acier	Date de dernière mise à jour: lundi 26 novembre 2018 09:32:35	
	No. DE PLAN PH400 - Plaque réservoir	
Cotes en mm		SAS HHO - France
1		3
2		2
3		3
4		4
5		5
6		6
A		A4
B		FEUILLE 1 SUR 1
C		FEUILLE 1 SUR 1
D		FEUILLE 1 SUR 1

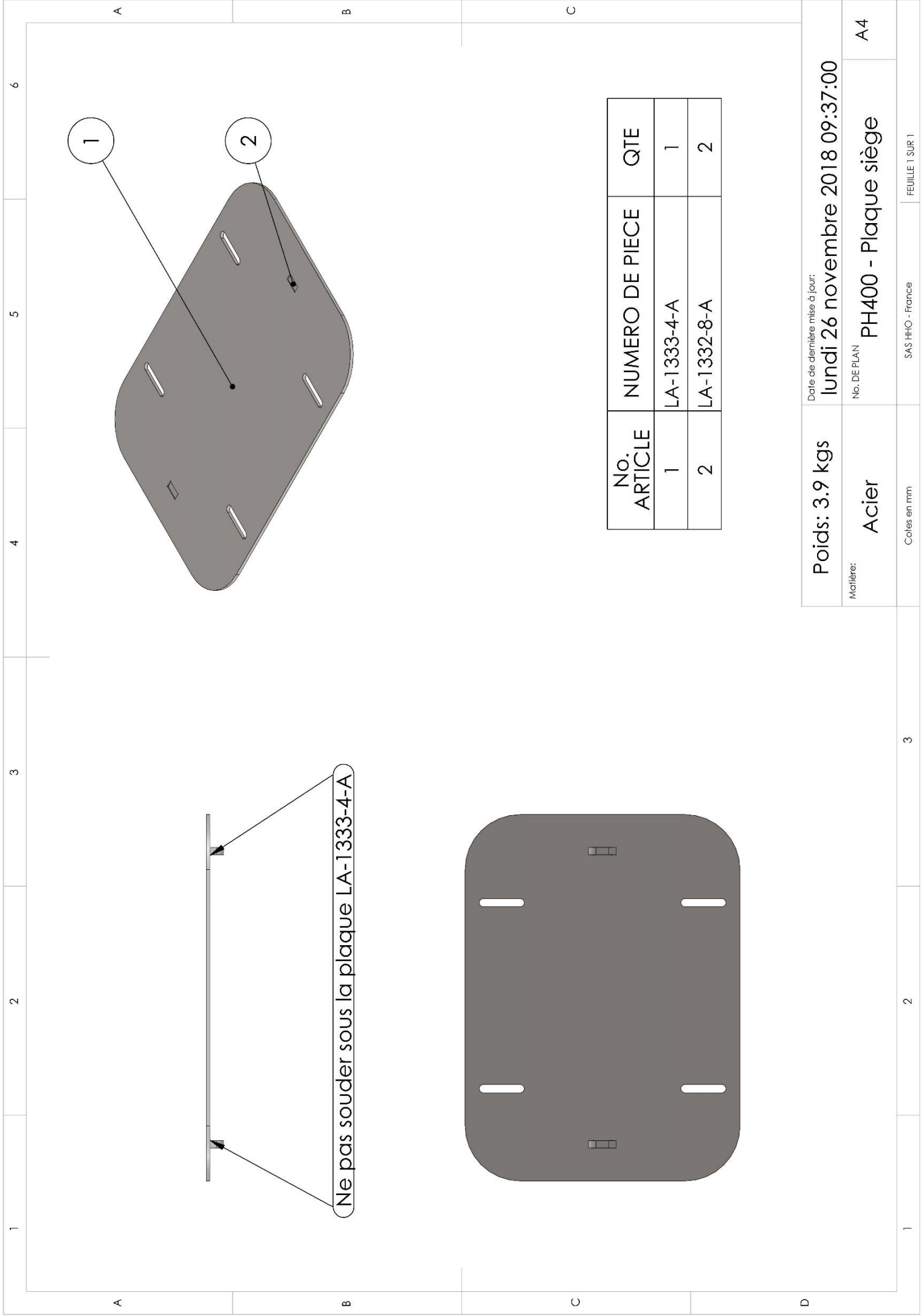

Ne pas souder sous la plaque LA-1333-4-A

No. ARTICLE	NUMERO DE PIECE	QTE
1	LA-1333-4-A	1
2	LA-1332-8-A	2

Poids: 3.9 kgs

Date de dernière mise à jour:

lundi 26 novembre 2018 09:37:00

Matériau:

Acier

No. DE PLAN

PH400 - Plaque siège

A4

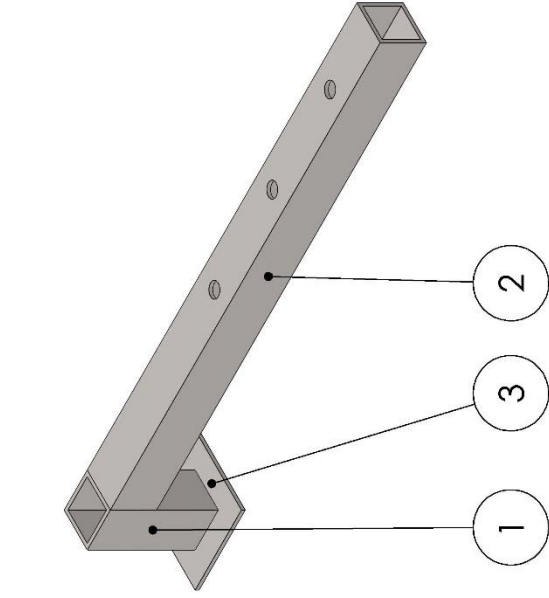
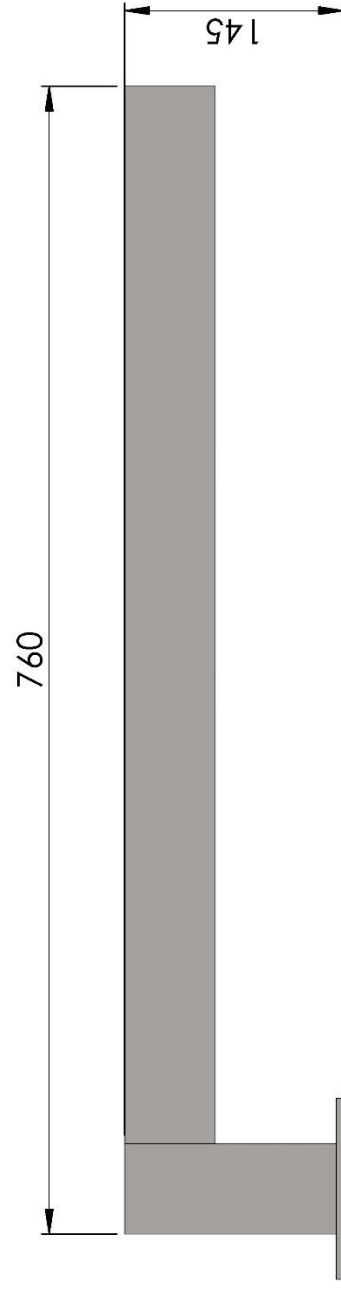
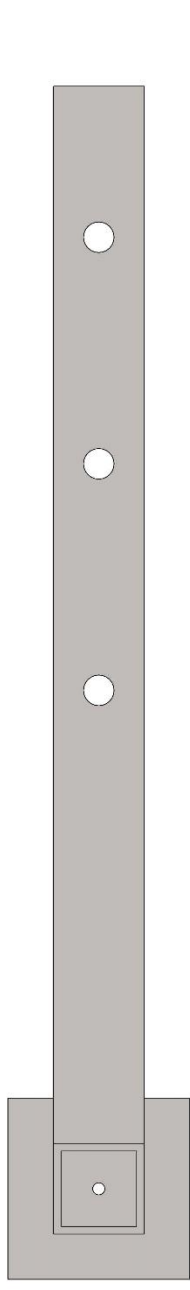

No. ARTICLE	NUMERO DE PIECE	QTE
1	TU-1077-5-A	1
2	TU-1076-5-B	1
3	LA-1313-5-B	1

Poids: 8 kgs

Matériau:

Acier

Date de dernière mise à jour:

jeudi 15 novembre 2018 16:58:03

No. DE PLAN

PH400 - Pieds stabilisateur

A4

Cotes en mm

SAS HHO - France

FEUILLE 1 SUR 1

6

5

4

3

2

1

A

B

C

D

1

2

3

1 2 3 4 5 6

A

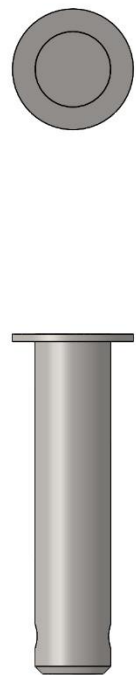

A

B

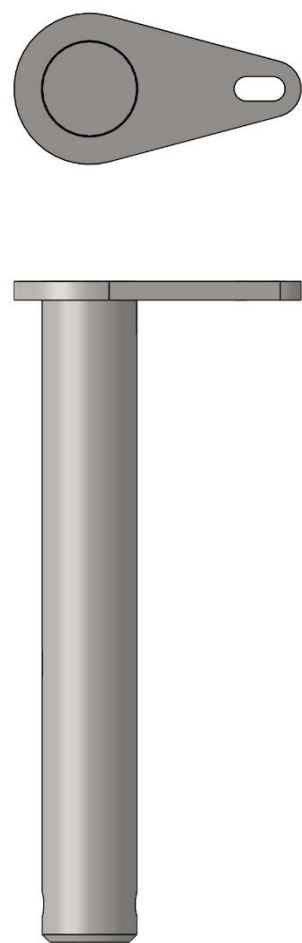

B

C

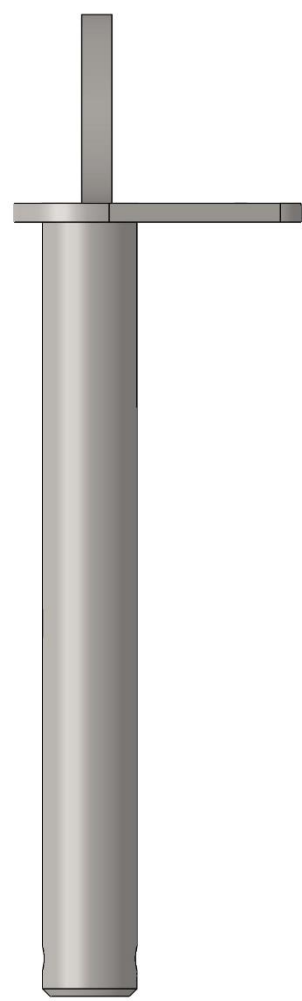

C

D

Soudure axes	Qte
Axe Ø20 lg 60 + goutte d'eau	2
Axe Ø20 lg 90 - 1P + Rondelle	1
Axe Ø20 lg 450 + goutte d'eau	1
Axe Ø25 lg 155 - 1P + goutte d'eau	7
Axe Ø25 lg 175 - 1P + Rondelle	2
Axe Ø25 lg 175 - 1P + Goutte d'eau	4
Axe Ø25 lg 210 - 1P + goutte d'eau	1
Axe Ø25 lg 210 - 1P + goutte d'eau + poignée	1
Axe Ø25 lg 450 + goutte d'eau	1

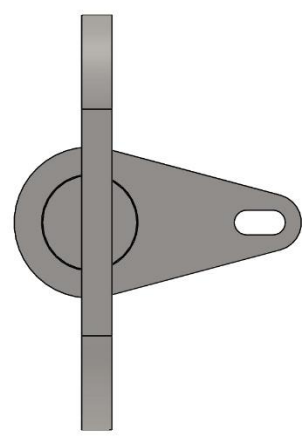

Date de dernière mise à jour:
jeudi 11 avril 2019 09:58:30

Matière: Acier

No. DE PLAN

Axes

A4

1

2

3

SAS HHO - France

FEUILLE 1 SUR 1

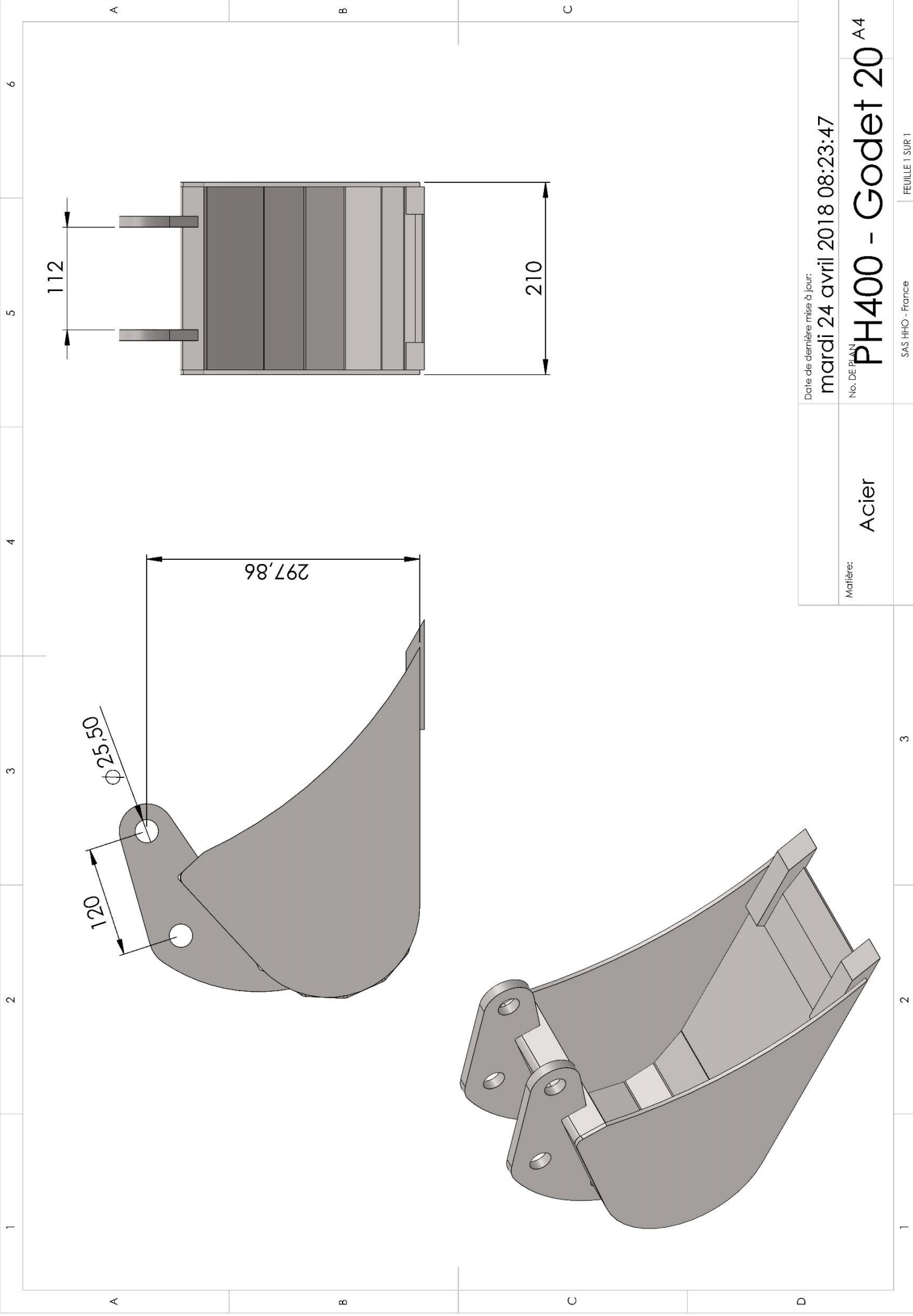

Date de dernière mise à jour: mardi 24 avril 2018 08:23:47	
No. DE PLAN PH400 - Godet 20 A4	Matière: Acier
SAS HHO - France	FEUILLE 1 SUR 1

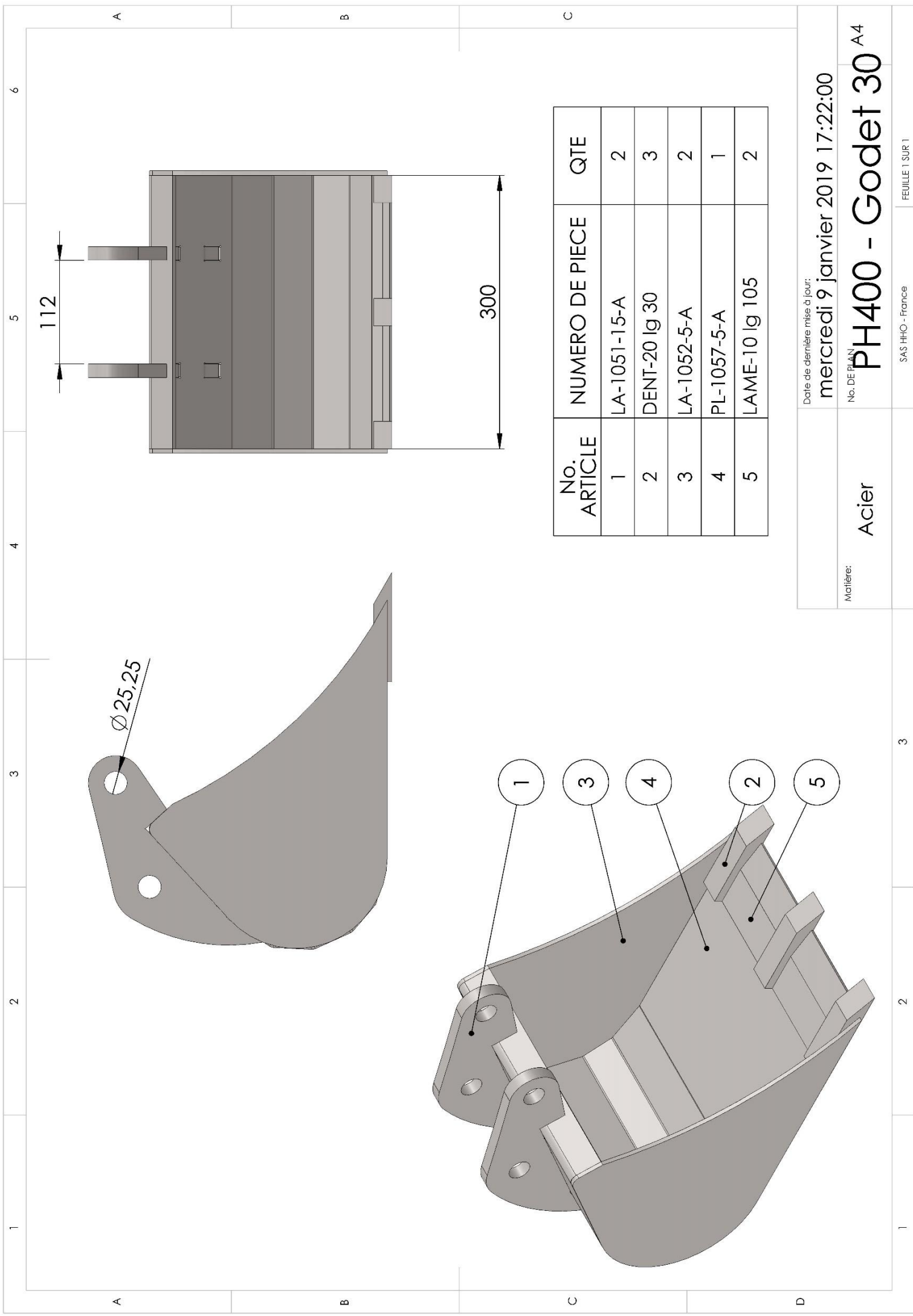

Date de dernière mise à jour:

mercredi 9 janvier 2019 17:22:00

Matériau:

Acier

Nc. DEPIAN

PH400 - Godet 30 A4

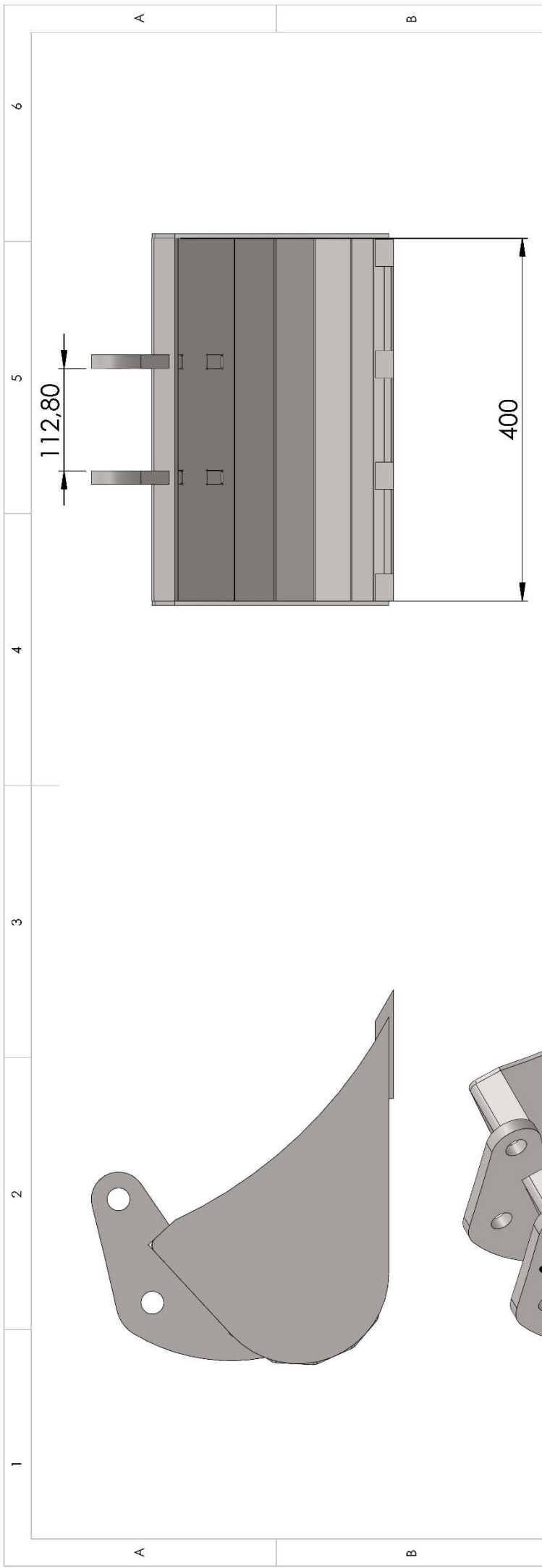

No. ARTICLE	NUMERO DE PIECE	QTE
1	PL-1119-5-A	1
2	LA-1051-15-A	2
3	DENT-20 lg 30	4
4	LA-1052-5-A	2
5	LAME-10 lg 93	3

Poids: 25 kgs

Matière: Acier

Date de dernière mise à jour: mercredi 9 janvier 2019 17:25:12

No. DE PLAN: PH400 - Godet 40

A4

Cotes en mm

SAS HHO - France

FEUILLE 1 SUR 1

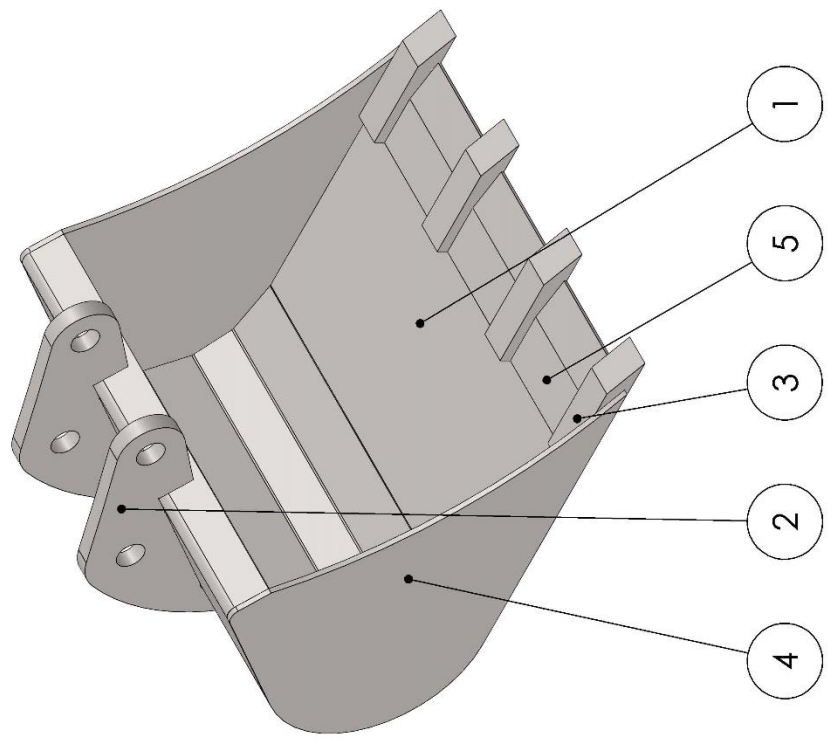

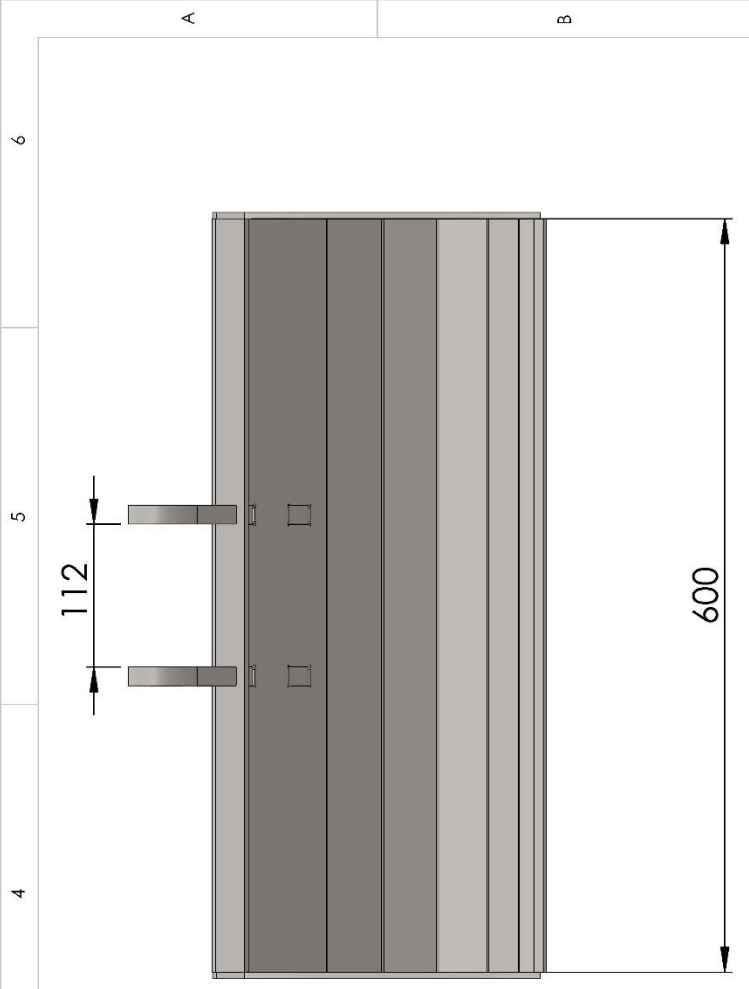

NO. ARTICLE	NUMERO DE PIECE	QTE
1	LA-1051-15-A	2
2	LA-1052-5-A	2
3	PL-1058-5-B	1
4	Lame 600	1

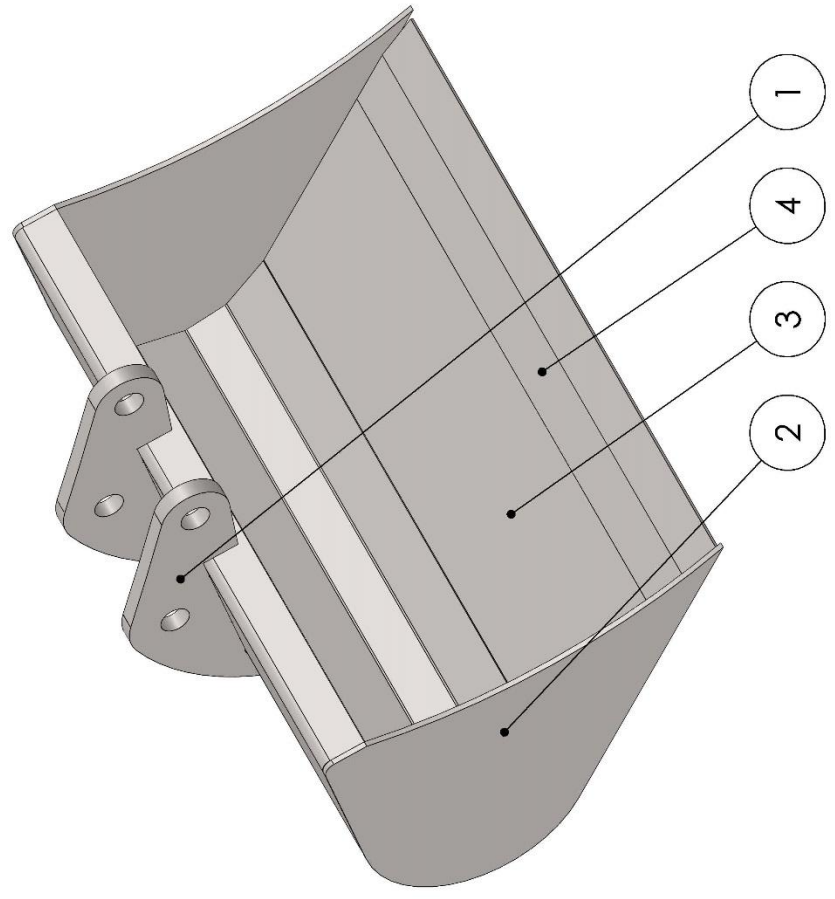
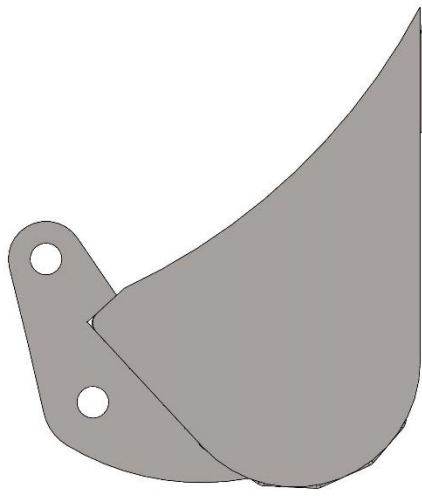

Poids: 35 kgs

Matériau: Acier

Date de dernière mise à jour:

mercredi 9 janvier 2019 17:19:29

No. DE PLAN

PH400 - Godet 60

A4

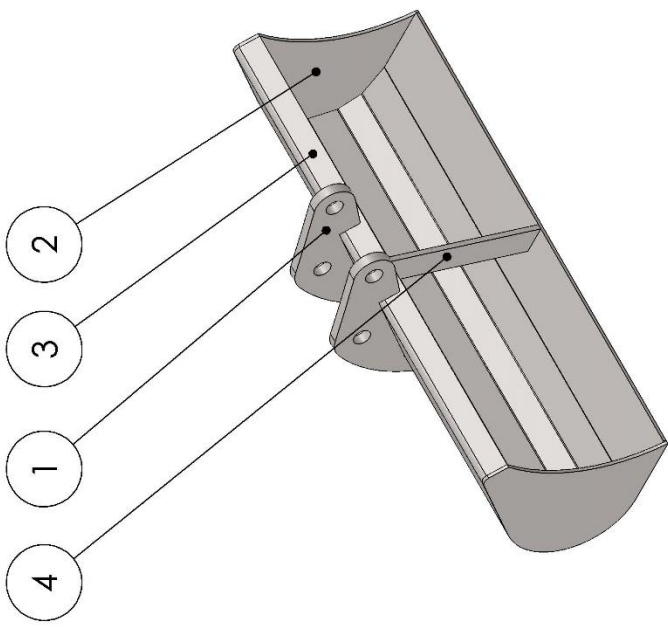
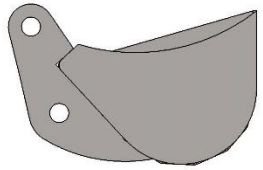
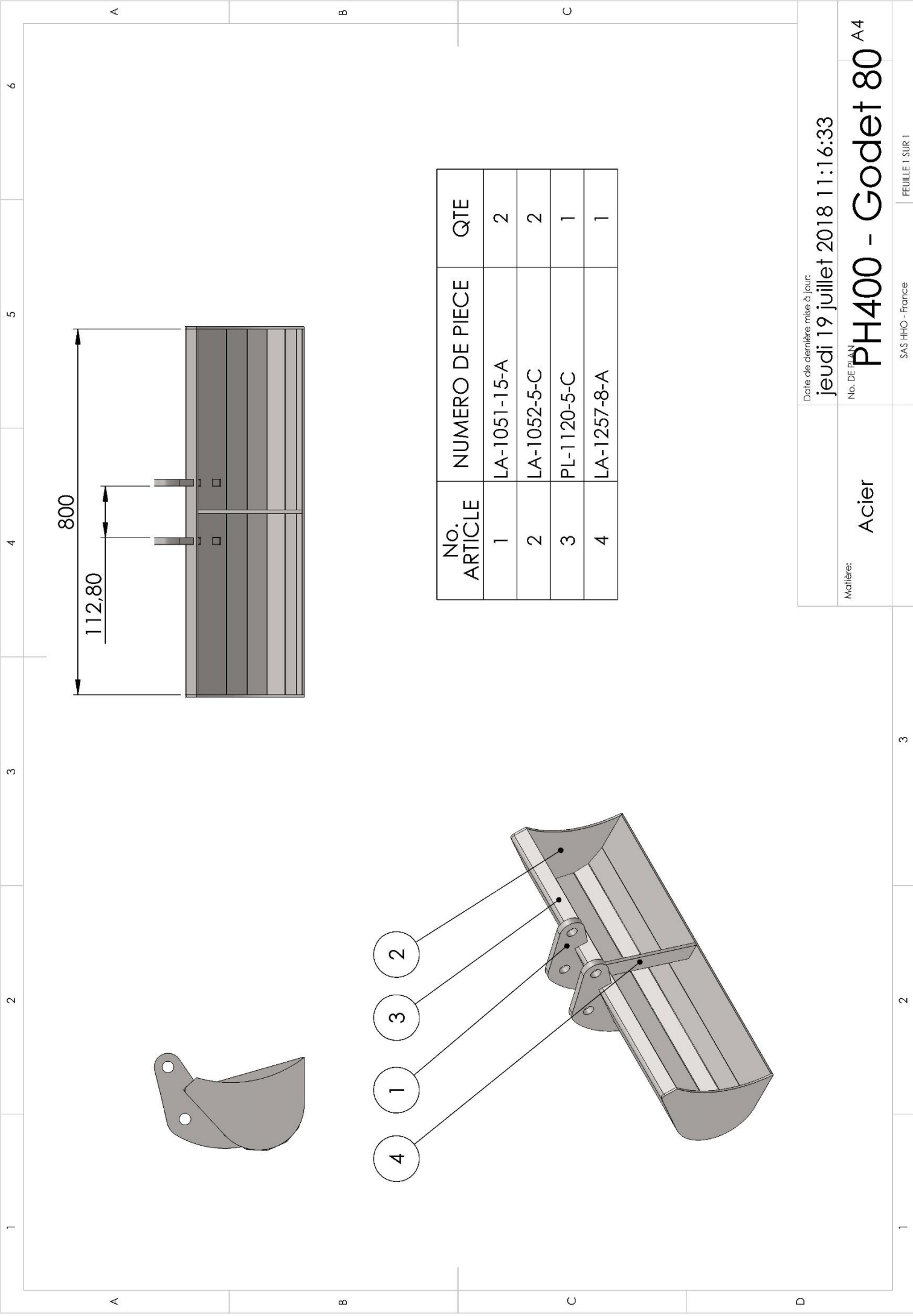

No. ARTICLE	NUMERO DE PIECE	QTE
1	LA-1051-15-A	2
2	LA-1052-5-C	2
3	PL-1120-5-C	1
4	LA-1257-8-A	1

Date de dernière mise à jour:
jeudi 19 juillet 2018 11:16:33

No. DE PLAN
PH400 - Godet 80 A4

Matière:
Acier

SAS HHO - France

FEUILLE 1 SUR 1

A

B

C

D

A

B

C

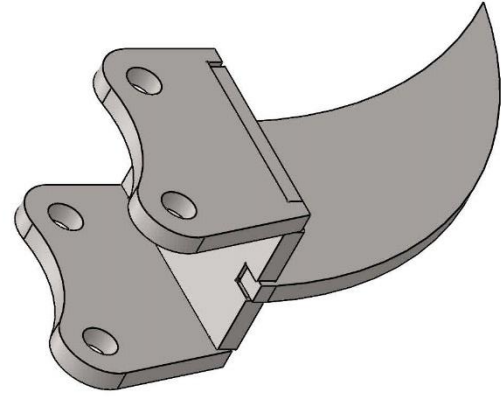
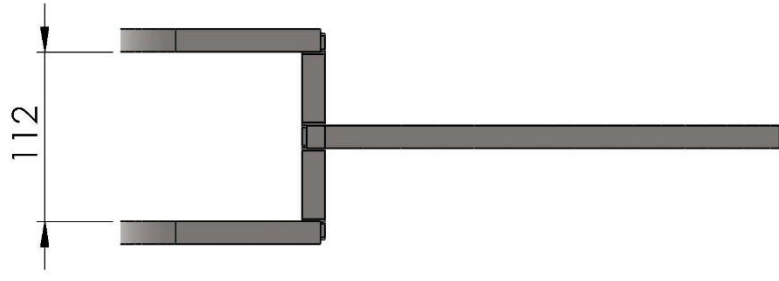
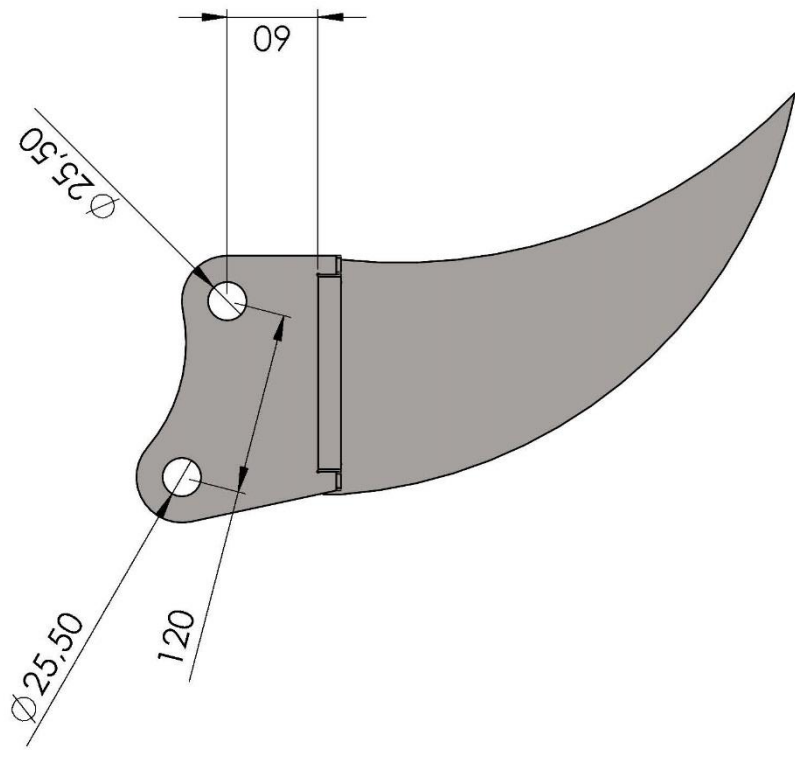

Date de dernière mise à jour: mercredi 7 mars 2018 12:01:39	Matière: Acier	No. DE PLAN PH400 - Dent ripper^{A4}
SAS HHO - France	FEUILLE 1 SUR 1	3

1 2 3 4 5 6

A

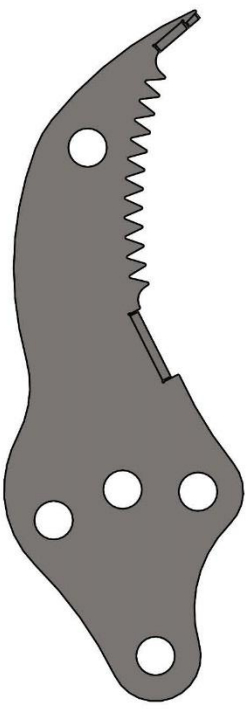

A

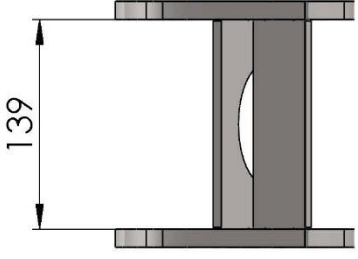

B

3

1

2

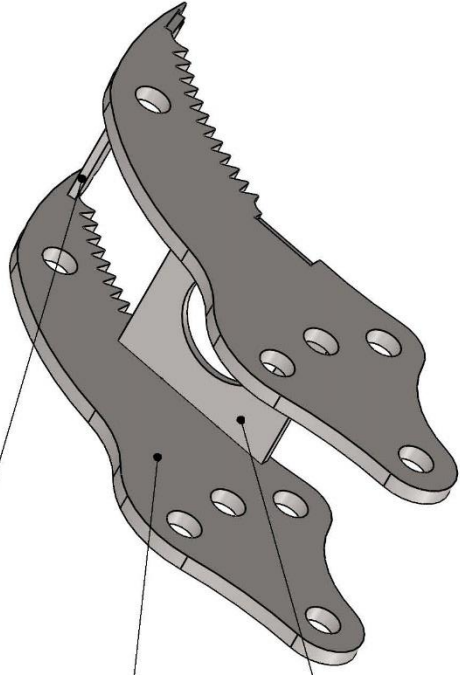

B

C

No. ARTICLE	NUMERO DE PIECE	QTE
1	LA-1193-12-A	2
2	LA-1194-6-A	1
3	LA-1196-6-A	1

C

D

Date de dernière mise à jour:

jeudi 23 novembre 2017 09:21:07

Matière:

Acier

No. DE PLAN

Griffe Manutention A4

1

2

3

SAS HHO - France

FEUILLE 1 SUR 1

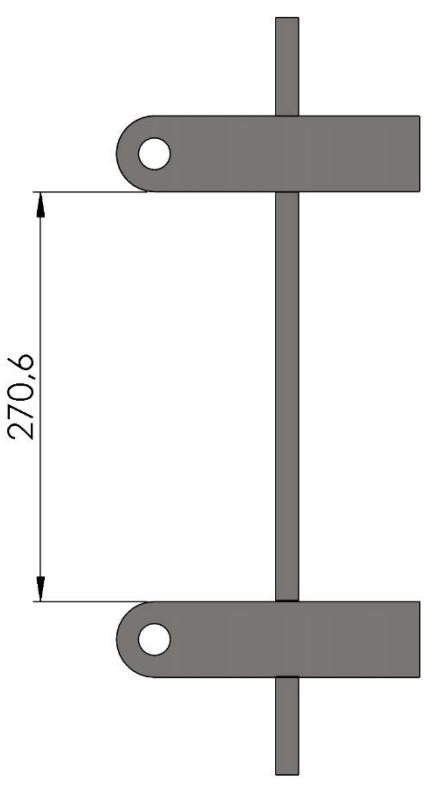
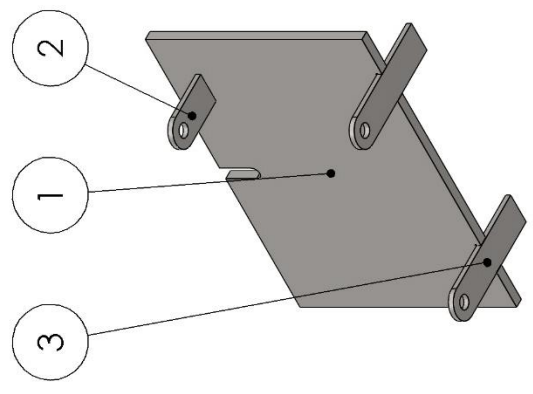
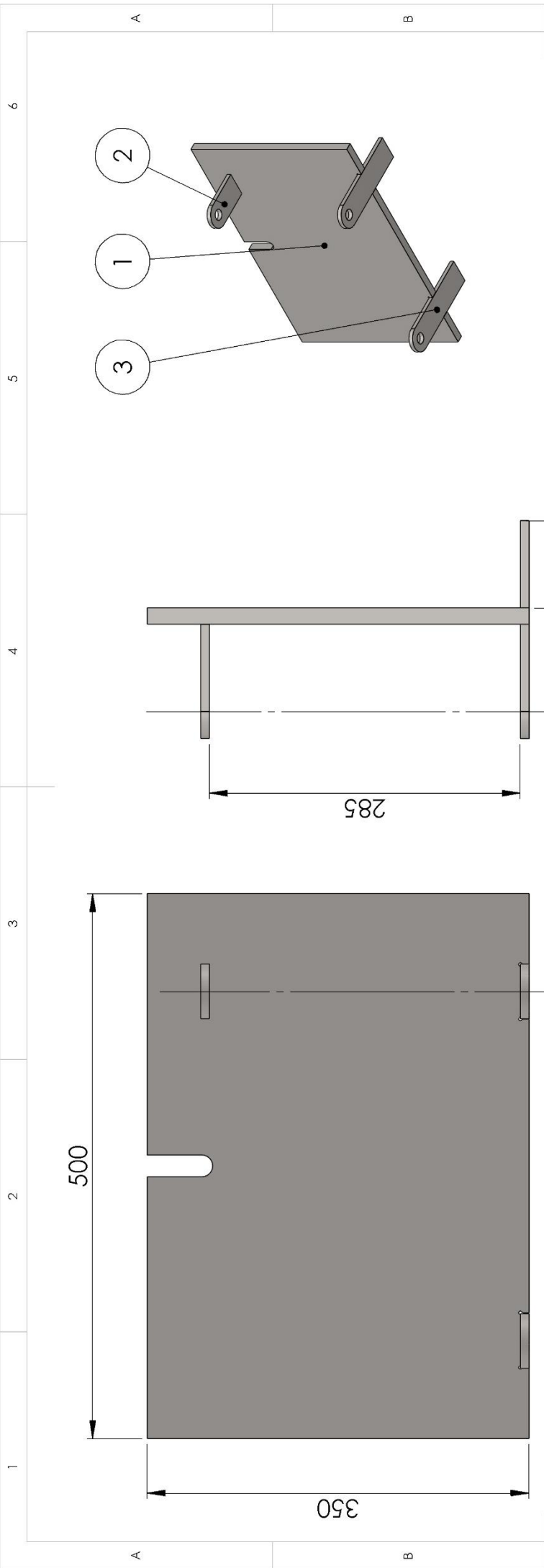

NO. ARTICLE	NUMERO DE PIECE	QTE
1	LA-1389-15-A	1
2	LA-1230-8-B	1
3	LA-1229-8-B	2

TITRE:

Support contre poids

Date:

03/05/2019

A4

ECHELLE:1:5

MATERIAU: Acier S.235

SAS HHO - France

2

1

FEUILLE 1 SUR 1

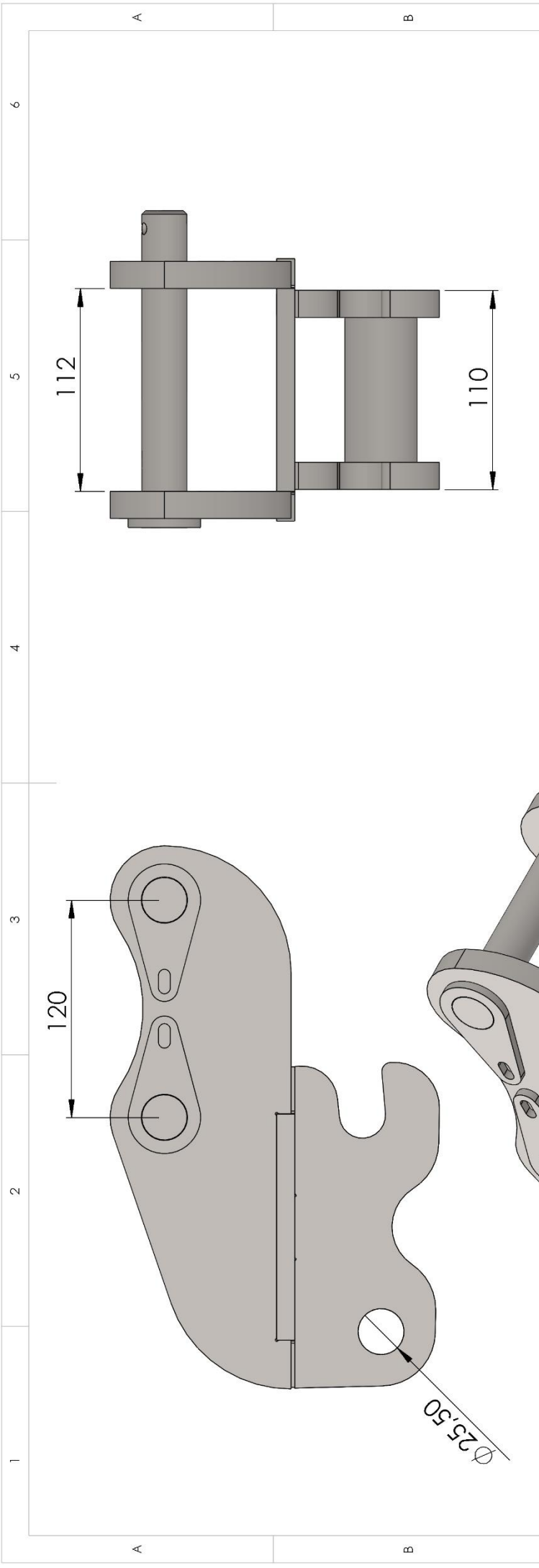

No. ARTICLE	NUMERO DE PIECE	QTE
1	LA-1382-10-A	1
2	LA-1381-15-A	2
3	LA-1380-15-B	2
4	bague Ø25 lg 80	1
5	A-25 lg 175-1	2
6	LA-1072-5-A	2

TITRE:

Attache rapide

Date:

03/04/2019

A4

Casser fortement les angles extérieurs pour que les soudures des godets ne gene pas

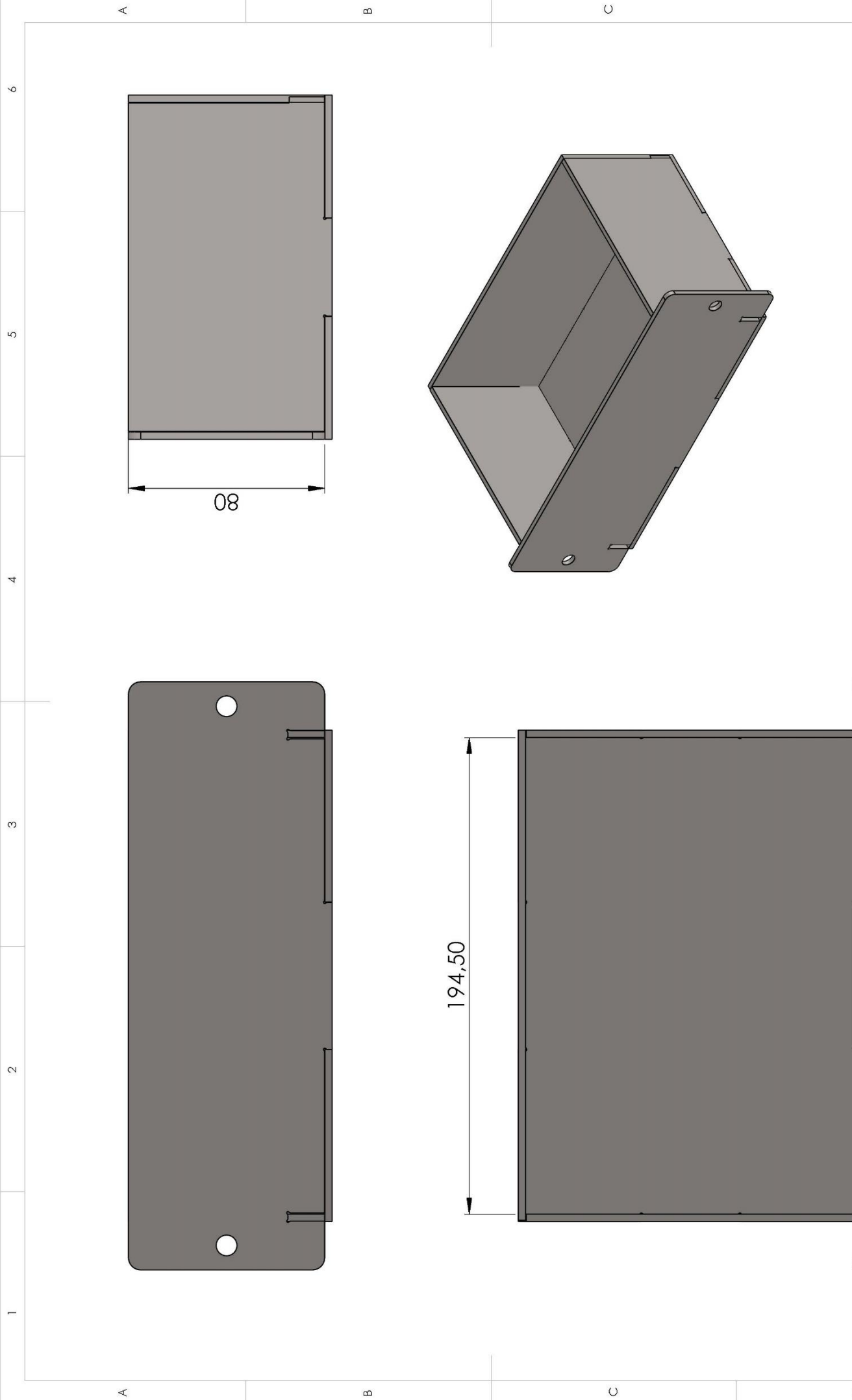

Date de dernière mise à jour: mercredi 15 mars 2017 09:05:43	
Matière: Acier	No. DE PLAN Support batterie A4
SAS HHO - France	