



14 CV

ASSEMBLY MANUAL Part 2 - Assembly

Phoenix 400 14 hp Kohler motor – Version 2019

HHO-Canada Inc

2883 Rue King Est, door 3
J1G5J1 Sherbrooke, QC, Canada
Tel : (+1) 819-574-5192
Email : contact.hho.canada@gmail.com

Introduction

Before starting the assembly, please check the entire pallet to see if there are no missing parts. It is important to carefully read the entire manual before the beginning of the assembly in order to avoid any mistake or misunderstanding.

The assembly process has been simplified as much as possible, if you have any doubt, do not hesitate to contact us. We are available from Monday to Friday 8.30 am to 12am and 2pm to 5pm, by phone or mail (with picture if possible).

If a part seems damaged or non-compliant, please send us a picture by mail for verification. For any after sale service, please contact us by mail with the problem you have, along with a picture if possible, your address, phone number and the invoice number.

Do not hesitate to send us your remarks or suggestions to improve this manual and help us improve the quality of the service we offer.

We wish you well on the assembly and do not hesitate to contact us.



Assembly step by step

Our products are in constant evolution, even though we are regularly updating this document, it is possible that some pictures are not up to date and the part you have differs a little.

The pictures in this manual have been taken on several different assembly; the principles of assembly are the same as described here even if the picture differs from the part you may have received. If you have any doubts, do not hesitate to contact us.

Before beginning the assembly and to avoid any mistakes, it is important to know how a hydraulic distributor works, this part controls the alimentation of the cylinder and allows you to operate the excavator.

There is an input and an output, if you reverse them, the distributor is going to leak and you won't be able to operate the excavator.

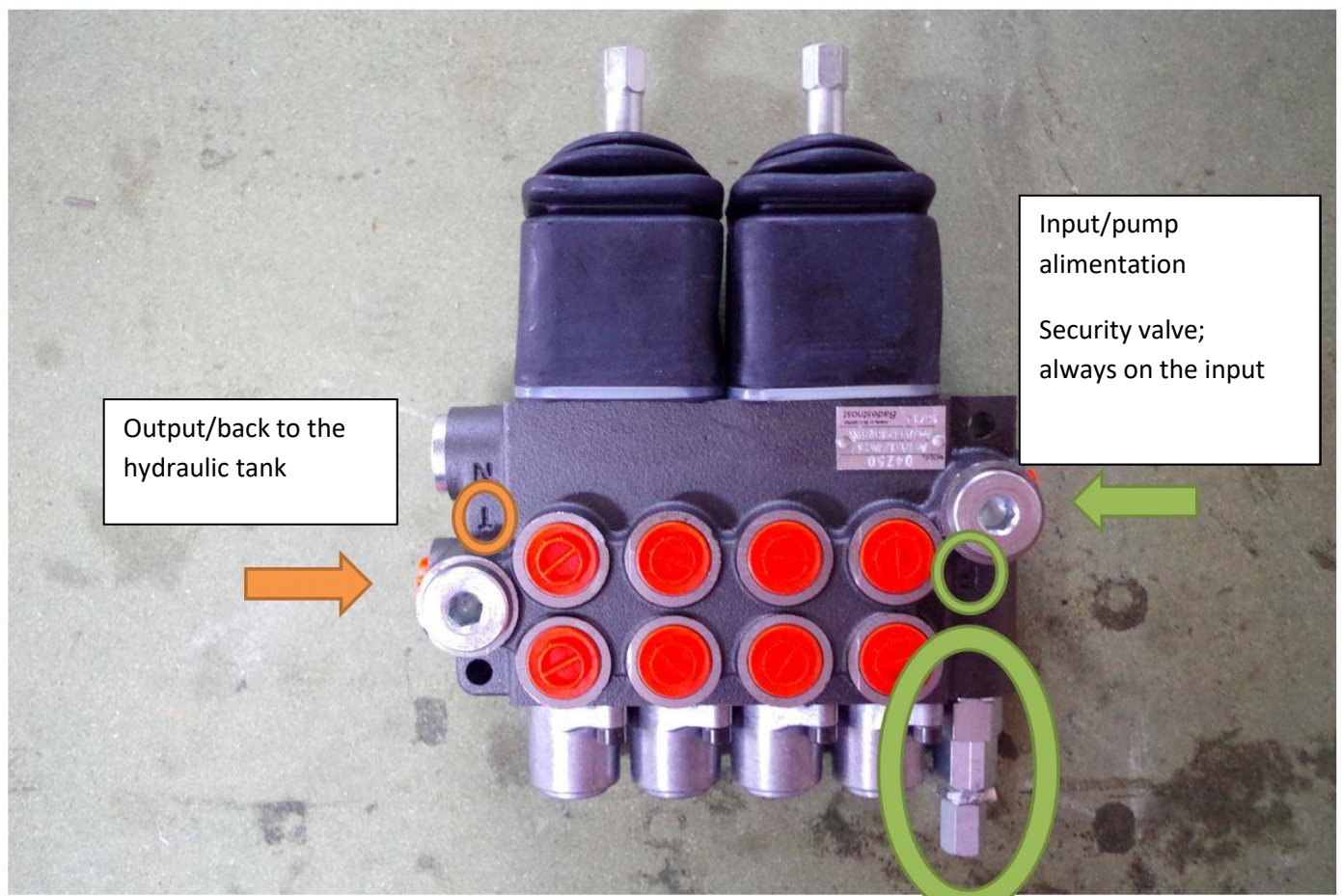

Banjo bolts need 2 copper washers, one on top and one at the bottom.



Screw in 2 grease fittings M6 straight on each side of the blade.

grease fitting M6 - qty 2



Install the blade with an $\varnothing 25$ mm length 435 mm teardrop pin from one side to the other of the base frame.

Lock the teardrop with 1 M6x16 bolt and thread locker.

Teardrop pin $\varnothing 25$ lg 435 GE - qty 1
Bolt 6 x 16 TH + thread locker - qty 1



Screw in the 4 fittings UM12L-12x17 on the cylinders VD25x40 c 100.

No need to add Teflon, the fittings already have an O-ring.

Cylinder 25x40 c 100 - qty 2
UM12L-12x17 - qty 4



Place the 25x40 c 100 cylinders in the frame with the fittings UM12L pointed downwards and fix the back of the cylinders with a teardrop shaft $\varnothing 20$ lg 435.

Verrouiller la goutte d'eau avec 1 vis M6x16 et du frein filet fort.

*Cylinder 25/40 c 100 - qty 2
Teardrop shaft $\varnothing 20$ lg 435 - qty 1
Bolt 6x16 TH - qty 1 + threadlocker*



Fix the head of the cylinders with 2 $\varnothing 20$ lg 60 teardrop shaft.

Lock the teardrops with 2 M6x16 bolts and threadlocker.

*Teardrop shaft $\varnothing 20$ lg 60 - qty 2
Bolt 6x16 TH - qty 2 + threadlocker*



Connect the hoses to the T 12L and the T 12L to the distributor according to the diagram page 36-37.

*T12L - qty 2
Hoses N° 17, 18, 19, 20, 21, 22*



Install 2 hydraulic motors OMR200 on the frame with 2 M12x50 bolts with 2 brake nuts for each motor.

*Hydraulic motor OMR200 - qty 2
12x50 bolts - qty 4
M12 brake nuts - qty 4*



Put with teflon 2 reductions MC1/2-F3/8 on each motor.

Careful, the reductions are fragile, do not overtighten.

MC1/2-F3/8 - qty 4 + teflon

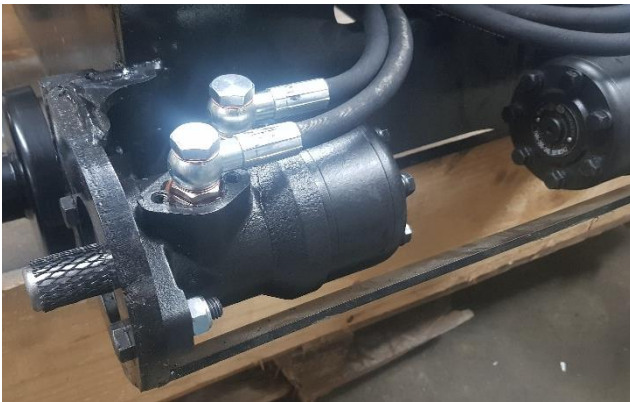

Connect the hoses to the hydraulic motors.

*VC17 - qty 4
JC17 - qty 8
Hoses n° 23, 24, 25, 26*



Install the rotary joint support plate at the center of the frame.

*RJ Plate - qty 1
8x30 bolts - qty 4
M8 Brake nuts - qty 4
Washer Ø8 - qty 8*

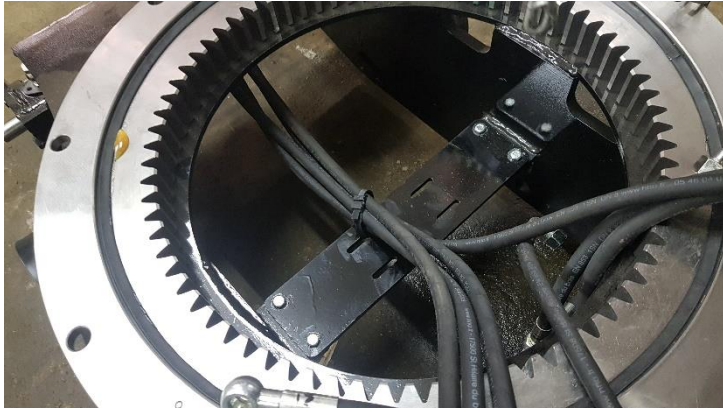

Assemble the hoses together and attach them to the central plate, leave a little room to be able to move them a little later.

Cable ties 9x360 - qty 3 (not included)



Continue to tie the hoses together with several cable ties so that the ends of the hoses are all about the same level.

Cable ties 9x360 - qty 2 (not included)



Place the slewing ring on the frame and bolt it down with 16 M12x30 bolts
Put threadlocker on each bolt.

*Professionnal ring - qty 1
12x30 bolt - qte 16 + threadlocker*



Screw in the 4 16x100 bolts on the front axle with a lock nut on each one.

*Ø35 axle - qty 1
16x100 bolt - qty 4
M16 nut - qty 4*



Insert a Ø42 lg 55 tube on each side of the front axle to space the rollers.

Ø42.4 lg 55 Tube - qty 2



Place the Ø240 – 35 rollers on each side of the axle with a washer between the tube and the roller. Adding some grease facilitate the insertion.

*Ø240 – 35 roller - qty 2
Ø35 washer - qty 2*



Add 1 pin on each side so that the roller does not slide off the axle.

Ø6 pin - qty 2



Insert the roller's shafts :

1 $\varnothing 25$ lg 740 pre-drilled shaft at the center

2 $\varnothing 25$ lg 175 teardrop shafts at the back of the frame.

*$\varnothing 25$ lg 740 shaft - qty 1
 $\varnothing 25$ lg 175 teardrop shaft - qty 2*



Lock the teardrops at on the other side with 2 M6x16 bolts and threadlocker.

6x16 bolt - qty 2 + threadlocker



To ease the installation of the rollers, one can sand the shafts and coat them with grease.



Place the rollers on the frame :

Rollers $\varnothing 240 - 25$ at the center
 Rollers $\varnothing 160 - 25$ in the back

*Roller $\varnothing 240 - 25$ qty 2
 Roller $\varnothing 160 - 25$ qty 2*



Place 2 \varnothing 25 washer on each side of the roller before placing the pin.

It is important that the roller can move on the shaft.

*\varnothing 25 washer - qty 8
 \varnothing 6 pin - qty 6*

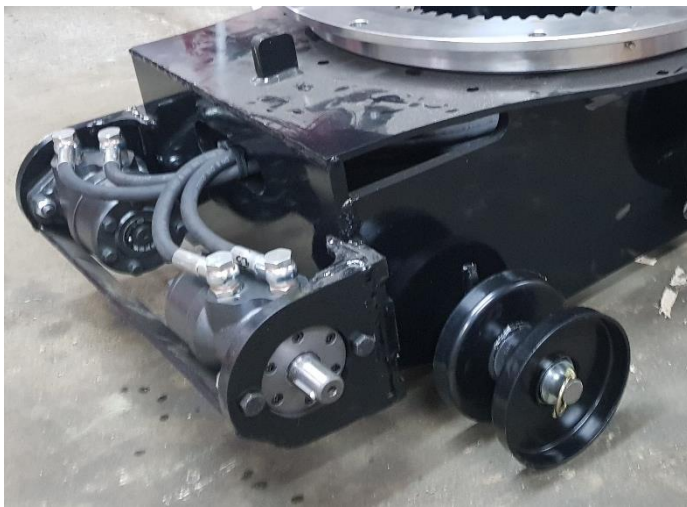

Before installing the rubber track, place the gear on the hydraulic motor and adjust if it need be.

Gear - qty 2



Lift up one side of the frame or the entire frame depending of the equipment available then put on the rubber tracks.

Rubber tracks 180x72x43 - qty 2



Place the gear in the track and pull it to fit the gear on the motor's shaft, be careful not to lose the key.

Lock the gear in place with 1 8x50 bolt with threadlocker and 1 large Ø8 washer.

*8x50 bolt - qty 2+ threadlocker
Ø8x40 washer - qty 2*



Slightly stretch the tracks, wait until the end of assembly to stretch them properly.



Place the turret on top of the frame while passing the hoses in its center.

Lock it in place with
1 M18x70 bolt in the swing bracket
7 M18x50 on the turret
2 M18x50 in the tank (see below)

*18x70 bolt - qty 1
18x50 bolt - qty 7
Ø18 washer- qty 8
M18 lock nut - qty 8*



Place 2 18x50 bolts with copper washers and teflon in the tank, lock then tightly in place to avoid any leaks.

*18x50 bolt - qty 2 + teflon
Copper washer Ø17 - qty 2
M18 lock nut - qty 2*



Check if the tank is clean, if not, wash it to take off any impurities that may end up in the oil.

Screw in the 2 metals strainer through the wall with with a Ø19 fluted tip -3/8 and a copper washer.

Add enough teflon to avoid any leaks.

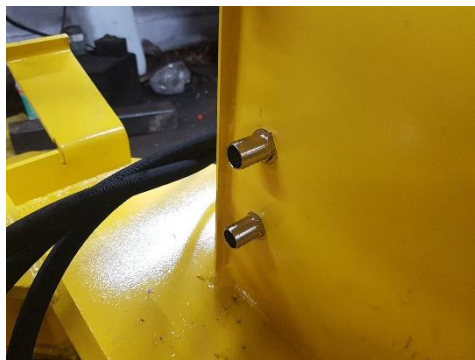

*Ø80 metal strainer - qty 2
Ø17 copper washer - qty 2
EC19-MC3/8 - qty 2 + teflon*

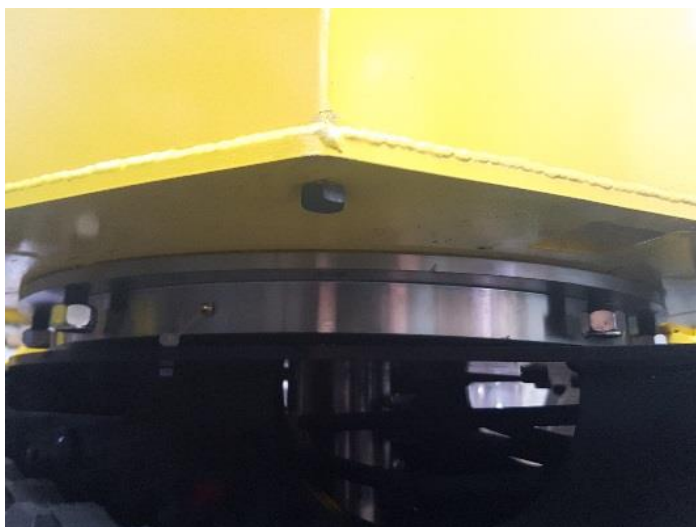

Place the drain bolt M12 x 20 with teflon at the bottom of the tank, screw it tightly in order not to lose oil when filling the tank.

12x20 bolt - qty 1 + teflon



Place the Hydraulic motor on the turret's rotation plate, be careful of the position as the plate is reversible and can be use for both the standard and professional slewing ring.

Hydraulic motor OMR200 - qty 1
Rotation plate - qty 1
12x50 bolt - qty 2
M12 lock nut - qty 2



Add the gear to the motor's shaft and lock it in place with a 8x50 bolt + washer and threadlocker.

M6 sprocket – 12D - qty 1
8x50 bolt - qty 1
Ø8x40 washer - qty 1



Turn the turret until you can see the green mark on the ring.



Place the hydraulic motor, be careful, it can have 2 position, one for the standard slewing ring (black) one for the professional (silver).

Install the place with 2 M12x20 bolts on the ring's side and 2 M12x30 bolts on the interior of the frame.

12x20 bolt - qty 2
12x30 bolt - qty 2

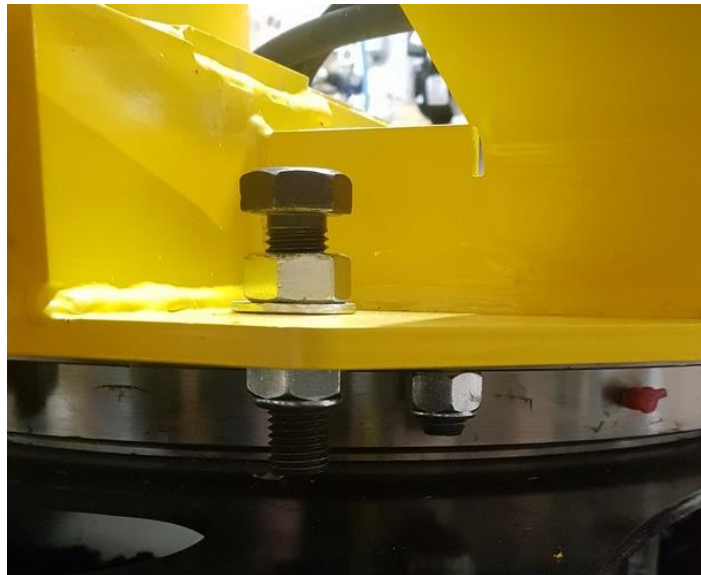

Turn back the turret to its original position and install the stop bolt; it can be placed on either side of the swing bracket.

Place the M20 x 80 with a locking nut to adjust the height.

Turn the turret and leave a ½ inch gap between the bottom of the bolt and the top of the base frame.

20x80 bolt - qty 1
M20 nut - qty 1
M20 locknut - qty 1



Install the distributor's support on the turret, the height can be adjusted later.

8x30 bolt - qty 4
M8 locknut - qty 4
Ø8 washer - qty 8



Place the 2 hydraulic distributors.

4 elements distributors - qty 2
 8x50 bolt - qty 4
 M8 locknut - qty 4
 Ø8 washer- qty 8



Warning, the distributors have a unique operating way.

The input is always where the safety valve is (circled in green).
 It can also be confirmed with the « P » carved into the distributor.

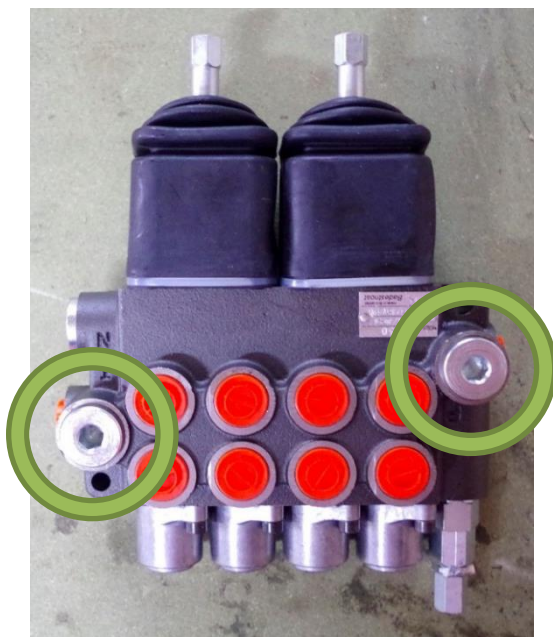

On the front of the distributor, take off the 2 metal plugs and put them on the sides instead of the red plastic plugs.



Place the fittings on the distributors.
4 union fitting 12x17 on the top row

These fitting already have an o-ring and do not need teflon to be installed.

UM12L12x17 - qty 8
UM12L15x21 - qty 4



Place the 2 elements distributors at the back of the turret. One joystick spring back in position, put a bypass on this one, the other one stays in place, connect this one according to the guide p 40.

D2 – lock -qty 1
8x60 bolt – qty 2
M8 locknut – qty 2
Ø8 washer – qty 2
UM12L12x17 – qty 2
UM12L15x21 – qty 2
VC17-12x17 -qty 1
JC17 -qty 2
Hose n°33



Install the flow divider under the turret's top with 2 6x60 bolts and locknuts, connect a UM12L-12x17 on each output.

Flow divider – qty 1
6x60 bolt – qty 2
M6 locknut – qty 2
Ø6 washer – qty 6
UM12L-12x17 – qty 3



Connect the hoses by following the instructions on page 36-37.

*VC17 - qty 3
JC17 - qty 6*



Place the reduction with teflon then connect the hoses to the distributor.

*MC1/2-F3/8 - qty 4 + téflon
Hose n°13, 14
VC17-12x17 - qty 3
JC17 - qty 6*



Place the slewing bracket with a Ø25 lg 210 shaft in the center and a Ø25 lg 210 shaft with a handle on one of the sides.

*Bracket PH400 - qty 1
Ø25 lg 210 teardrop shaft - qty 1
Ø25 lg 210 shaft + handle - qty 1*



Install the boom and a 30/60 c 300 cylinder with the fitting pointing upward.

Center the boom and the cylinder using $\varnothing 25$ washers as shims on each side.

*Boom - qty 1
 30/60 c 300 cylinder - qty 1
 $\varnothing 25$ lg 155 teardrop shaft- qty 3
 $\varnothing 25$ washer - qty 4
 $\varnothing 6$ pin - qty 3*



Place a 30/50 c 300 cylinder on the boom.

Screw in 2 CM12L-12x17 elbow fittings with teflon ; orient them pointing toward the turret.

*30/50 c 300 cylinder - qty 1
 $\varnothing 25$ lg 155 teardrop shaft - qty 1
 $\varnothing 6$ pin - qty 1
 CM12L-12x17CO - qty 2 + teflon*



Install the arm and a 30/50 c 300 cylinder on it.

Screw in 2 CM12L-12x17 elbow fittings with teflon ; orient them pointing toward the turret.

*30/50 c 300 cylinder - qty 1
 $\varnothing 25$ lg 155 teardrop shaft - qty 1
 $\varnothing 6$ pin - qty 1
 CM12L-12x17CO - qty 2 + teflon*



Install the brackets on the arm.

Do not put the bucket now, it will be easier later.

Arm bracket - qty 1
Bucket bracket - qty 1
Ø25 lg 175 + GE teardrop shaft - qty 2
Ø6 pin - qty 2

Motor assembly

The general principle is the same for every motor, only some small part may differ depending on the motor.



Fill up the oil level, there is 2 plugs on either side of the motor.
One of the plugs has a gauge to check oil level.
Take the key off the keypath, add some gas in the tank and start the motor to check if there is no problems.

*Kohler CH395 motor - qty 1
Oil 5W30 (not included)*

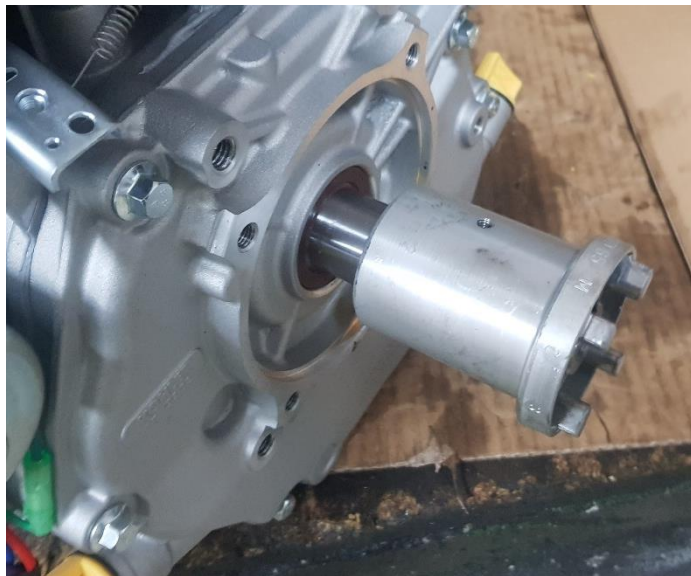

Put the key back on the keypath and install the elastic coupling on the shaft.

Half elastic coupling - qty 1



Place the lantern with 4 5/16 chromed bolts and threadlocker.

The long side of the lantern should be pointing upward.

Lantern 90 G1 - qty 1
5/16 x 1"1/4 bolt - qty 4 + threadlocker



Place the centering washer on the pump.

Double pump 3.2+3.2 G1 - qty 1
Centering washer - qty 1



Install the other half of the elastic coupling, making sure that the key does not fall off the keypath of the pump's shaft.

Carefully fit it in with a wooden mallet or with a hammer and a wood piece.

Place the washer and the nut with threadlocker.

Half elastic coupling - qty 1
Pump nut - qty 1
Pump washer- qty 1



Place the rubber star on the elastic coupling of the motor.

Rubber coupling star - qty 1



Place the pump on the lantern with 4 BTR 8x30 bolts and threadlocker.

8x30 BTR bolt - qty 4 + threadlocker

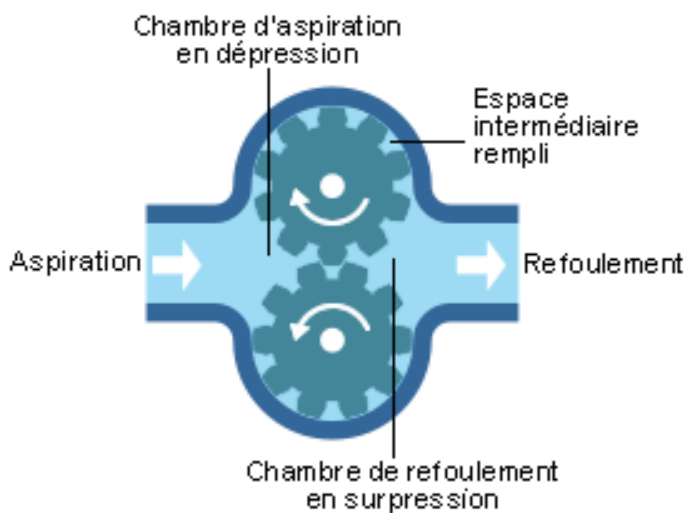

Before locking the lantern in position, check the direction of rotation of the pump, for this, take off the plugs and slowly pull on the motor's starter rope. Look from on side in the pump :

- If the gear a turning toward each other, it is the output and you need to connect this side to the distributor.
- If the gears are turning away from each other, it is the input and this side must be connected to the tank.



Crimp or solder the terminal to the electric wire.

On the 25-30 cm wire, 1 Ø8 + 1 Ø6 terminal

On the 45-50 cm wire, 2 Ø6 terminals

Electric cable 16² lg 26 cm - qty 1

Electric cable 16² lg 50 cm - qty 1

Ø8 terminal - qty 1

Ø6 terminal - qty 3



Connect the 25 cm cable to the mass at one of the motor's casing bolts.

Electric cable 16² lg 26 cm - qty 1

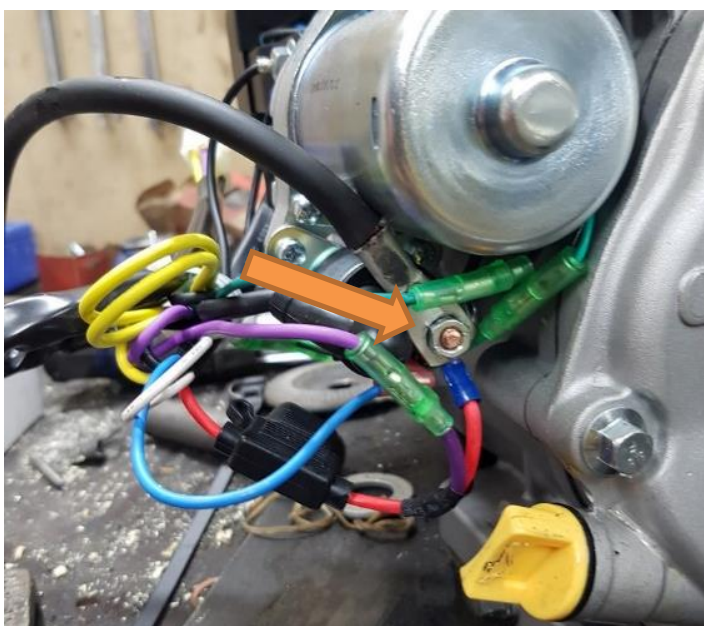

Connect the + to the back of the coil where the red cable is already connected.

Warning, the terminal should not be in contact with anything other than the bolt and wires connected to the same bolt.

Electric cable 16² lg 50 cm - qty 1



Connect the cable to the battery.

*6x25 bolt - qty 2
M6 nut - qty 2*



Install the radiator support plate.

*radiator support plate – qty 1
8x20 bolt- qty 2
M8 locknut - qty 2
Ø8 washer - qty 4*



Install the radiator.

*Radiator – qty 1
8x20 bolt – qty 4
M8 nut – qty 4
Ø8 washer – qty 8*



Place the reduction fittings on the radiator.

1'1/2 – 1/2 reduction fitting – qty 2



Install the union fitting on the reductions.

UM12L-15x21 – qty 2



Connect the hoses from the distributor to the radiator then to the tank. See Diagram page 36-37.

Hoses n°29 and 30



Take off the protection of the side and plug in the alimentation cable.

Do not forget to put on the protective cap before plugging in the cable.

Electric cable radiator – qty 1

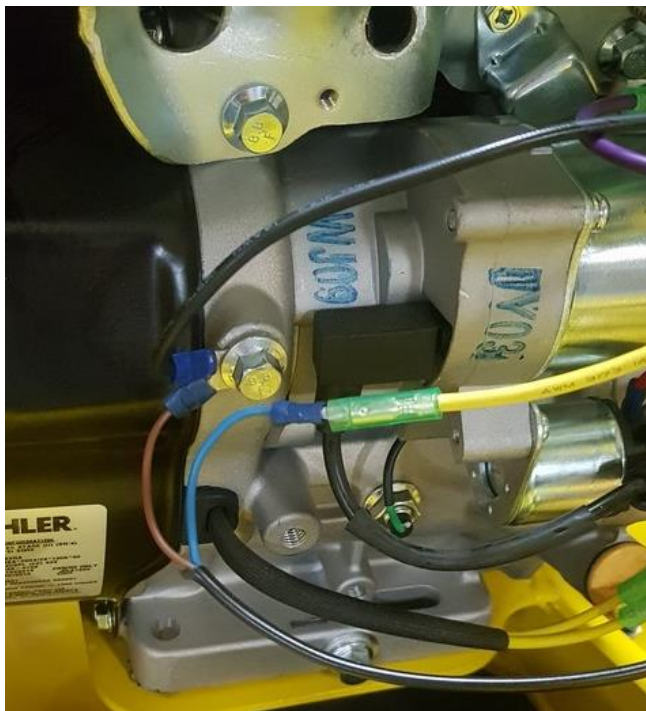

Connect the cable to the Kohler motor, the brown cable to the mass and the blue cable to one of the motor's yellow cable (+12 V after ignition).



Information

It is possible to pass the hoses through the frame and in the boom.

If you do so, it is important to protect them with a sleeve in order to avoid any premature wear and tear.

Protective sleeves are not included in the kit.



For an easier installation, always connect the hoses starting from the distributor and going to the cylinder/motor.

Connect the boom's hoses with banjo bolts and 2 copper washers directly in the cylinder's bosses.

*hoses n° 7 and 8
banjo bolt VC17-12x17 - qty 3
copper washer JC17 - qty 6*



Connect the hoses to the arm.

*Hoses n°9 and 10
VC17-12x17 - qty 1
JC17 - qty 2*



Install the hose guide to maintain them on the boom :

Place a 8x100 bolt under the boom and screw in the base plate of the guide on the other side.

Place one half of the guide then place the arm's hoses in and the other half on top.

Place another half guide and place the hoses 11 and 12 cap it with the last half guide, the metal upper part and lock it with a locknut.

Do not tighten it too much for now.

8x100 bolt - qty 1
Hose guide - qty 1
Half guide - qty 2
M8 locknut - qty 1



Install tightly the quick coupler on the hoses 11 and 12 with teflon.

It is best to have a male and female connection on each side in order to not have any doubt when unplugging/plugging them in the futur.

Hoses n°11, 11', 12, 12'
CCF1/2 - qty 2 + teflon
CCM1/2 - qty 2 + teflon
VC17-12x17 - qty 1
JC17 - qty 2



The line 15-16 is not use on the standard version, a small bypass is used.

To install this hose, first place the banjo bolt with 2 copper washers then bend the hose in place and connect the elbow.

Hose n°15
VC17-12x17 - qty 1
JC17 - qty 2



Install the auxiliary hydraulic line from the rear distributor and fix it on the side of the boom.

Hoses n°31 and 32
CCF ½ - qty 1
CCM ½ - qty 1
Hose guide – qty 1



Clean thoroughly the tank and fill it with hydraulic oil and install the tank plate with a rubber gasket and 4 bolts (final level will be done after starting the excavator).

Hydraulic oil HV46 - qty 35L (not included)
Tank plate ph400 - qty 1
Tank gasket - qty 1
M6x16 bolt - qty 4
M22 plug with gauge - qty 1

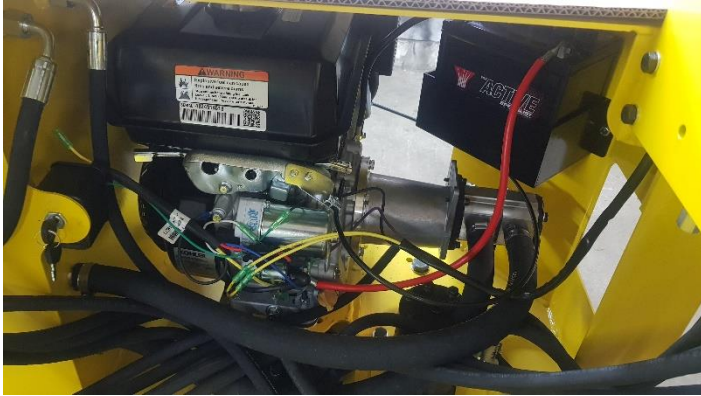

Check and tighten every hose if need be then start the motor a medium speed.

Operate **slowly** each functions of the distributor and look for any leaks.

After verification, operate each cylinder fully in and out to get rid of any air in the system.



Place the seat on the seat plate, the bolts are mobile, do not hesitate to move them for assembly.

Seat plate - qty 1
Seat - qty 1



Install the seat on the turret through the mortises and locking it with 2 pins.

Ø6 pins - qty 2



Once the system is tested, assemble all the hoses with cable tie.

Do not hesitate to put protective sleeves on hoses in contact with a sharp corner.

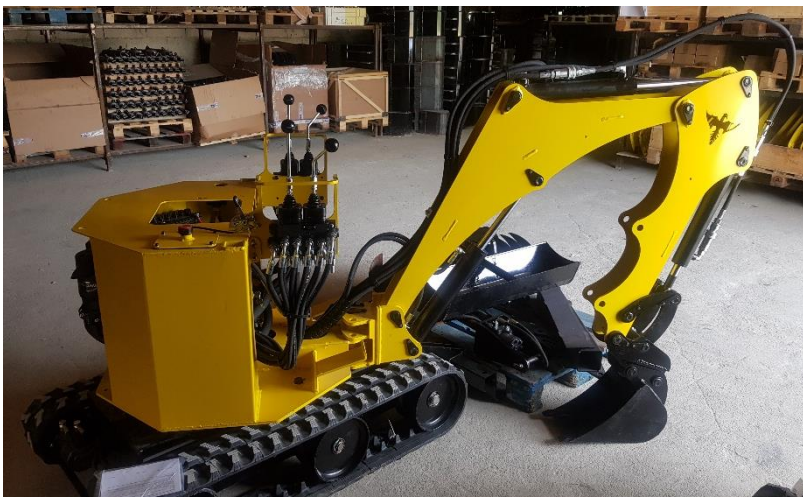

Check on every articulation of the arm so that the hoses have enough length to operate every movement without problems.



Tension of the tracks :

There is no ideal tension, this will depend on the land the excavator has to move on :

On a muddy land, the tracks should not be too stretched, it should be a little floppy on the center.

On a firm land, the tracks should be stretch almost straight (as on the picture)

Do not overtighten the tracks, this will result in premature wear and tear of the tracks and the hydraulic motors.



Place the first plate on the pivot axis with a $\varnothing 20$ lg 430 teardrop shaft and lock it with a 6x16 bolt on the turret.

Lock the other side with a 18x50 bolt + locknut.

Pile on the place depending on your needs and lock then together with a 18x100 bolt + locknut.

Support counterweight - qty 1

Plate counterweight - qty 4

Axe $\varnothing 20$ lg 430 teardrop shaft- qty 1

Vis 6x16 bolt - qty 1

18x50 bolt - qty 1

18x50 locknut – qty 1

18x100 bolt - qty 1

M18 locknut - qty 2

Before filling the tank, it is important to clean it to avoid having any debris/metal/dust tint the hydraulic system. The best way to clean it is with a wet clean rag then a magnet to get rid of any metallic particles.

If the pump is damaged because of a bad cleaning or maintenance of the hydraulic system, the warranty of this part as well as the warranty of the hydraulic motors may not be accepted.

After filling the tank with oil and starting the machine, it is possible to have a lack of power or that the motor stops while using any function, it will then be necessary to adjust the pressure.

To do so, take off the cap of the security valve then with an Allen key screw or unscrew the bolt circled in green :

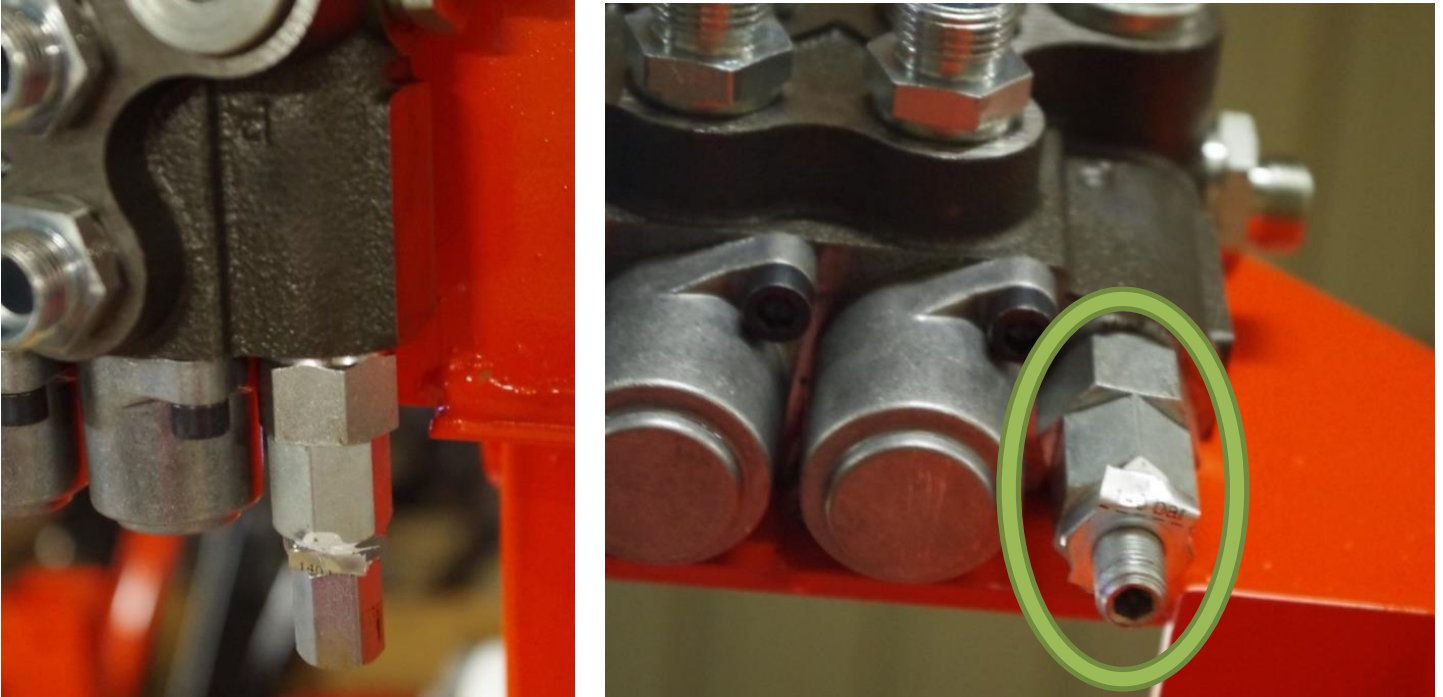

Ideally, you need to measure the pressure at the entry of the distributor, the pressure should be at 150 bar, if you do not have the necessary equipment do the following:

- If you lack power tighten the bolt $\frac{1}{4}$ turn at a time until you have enough pressure so that the hydraulic motors work properly. Do not overtighten, this may cause damages to the pump and other parts of the hydraulic system.
- If the hydraulic motors stop the engine when activated, the pressure is too high and you need to loosen the bolt $\frac{1}{4}$ turn at a time.

Check the oil level regularly, you need to drain the entire tank at least once a year.

Then maintenance schedule and procedure are listed in the user guide available on our website.

For the first hour of use, one should use the excavator in an open area to avoid collateral damages.

Do not hesitate to send us your comments about this guide in order to improve it.

Option quick coupler on the bucket



2 fittings AT12L-12x17 to screw on the cylinder's elbows then 2 UM12L-15x21 on the hoses.

Then connect the quick couplers as you wish.

This option allows the operator to use an auxiliary hydraulic attachment quickly.

AT12L-15x21 - qty 2
UM12L-12x17 - qty 2
CCF1/2 - qty 2
CCM1/2 - qty 2

Option Hydraulic line for telescopic arm



The hydraulic lines for the telescopic arm are 2 hoses connected from the distributor instead of the bypass 15-16 going to the telescopic arm.

Warning : option not compatible with the hydraulic line to the tip of the arm

Hose Ø8 lg 2550 C / MC1/2 - qty 1
Hose Ø8 lg 2500 B / MC1/2 - qty 1
CCF1/2 - qty 1
CCM1/2 - qty 1

Option hydraulic line to the tip of the arm



The hydraulic line to the tip of the arm are 2 hoses connected from the distributor instead of the bypass 15-16 going to the telescopic arm.

Warning : option not compatible with the Hydraulic line for telescopic arm

Hose \varnothing 8 lg 3800 C / MC1/2 - qty 1
Hose \varnothing 8 lg 3800 B / MC1/2 - qty 1
CCF1/2 - qty 1
CCM1/2 - qty 1
Hose guide - qty 1

Option Hourmeter



Install the hourmeter in the $\varnothing 50$ hole on the turret.

Hourmeter - qty 1



Plug the - terminals of the hourmeter to the terminal - of the battery.

Cable - - qty 1



Plug the + terminal of the hourmeter to one of the available yellow wire of the Kohler motor (the 2 yellow wires are + at 12 Volt).

Turn on the ignition and check if it is working properly, if not, reverse the 2 terminals of the hourmeter.

Cable + - qty 1

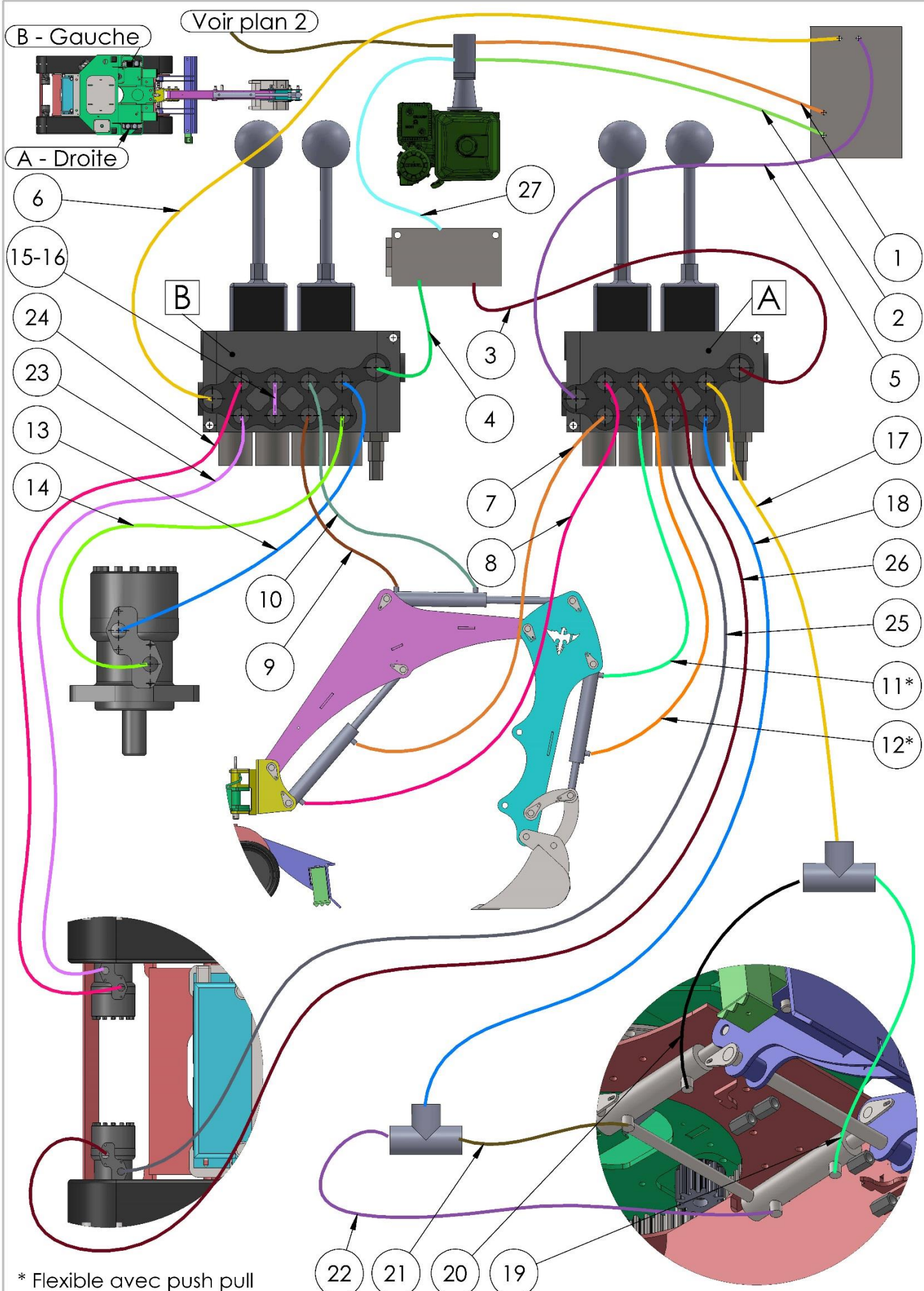

* Flexible avec push pull

B - Gauche

A - Droite

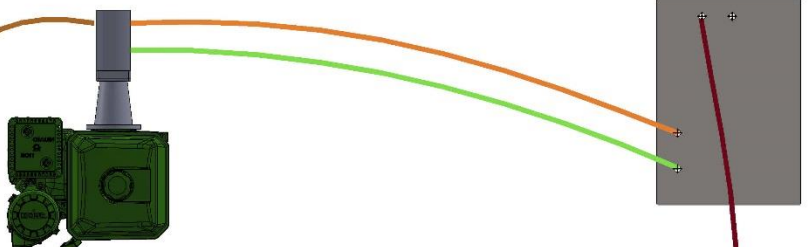
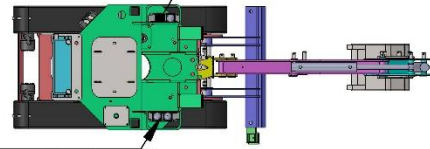

30

28

33

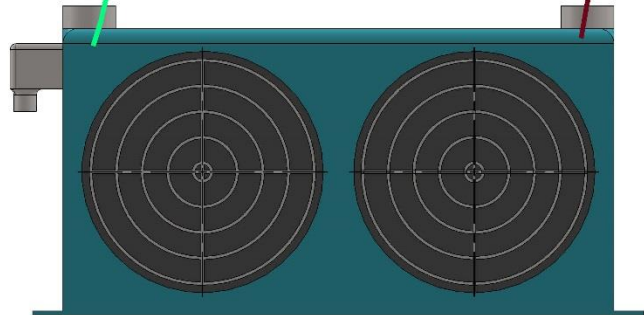
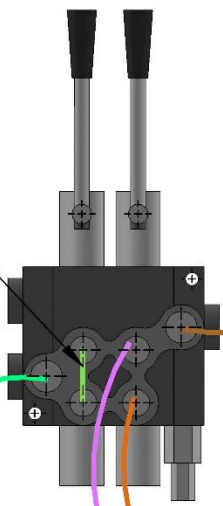

29

31

32

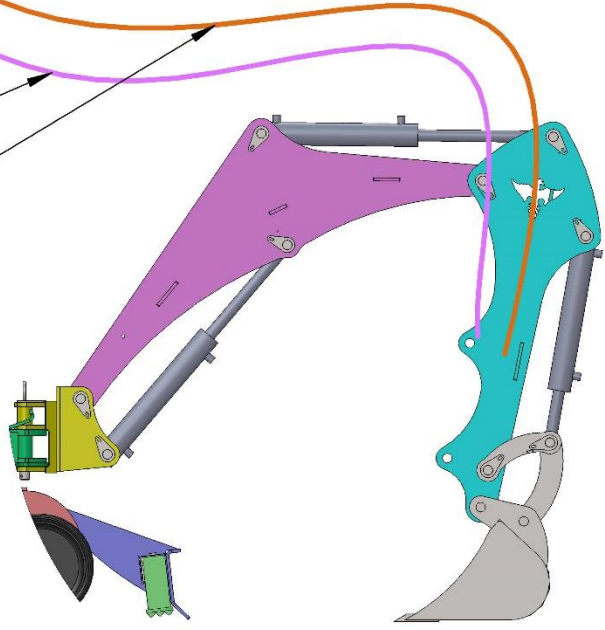

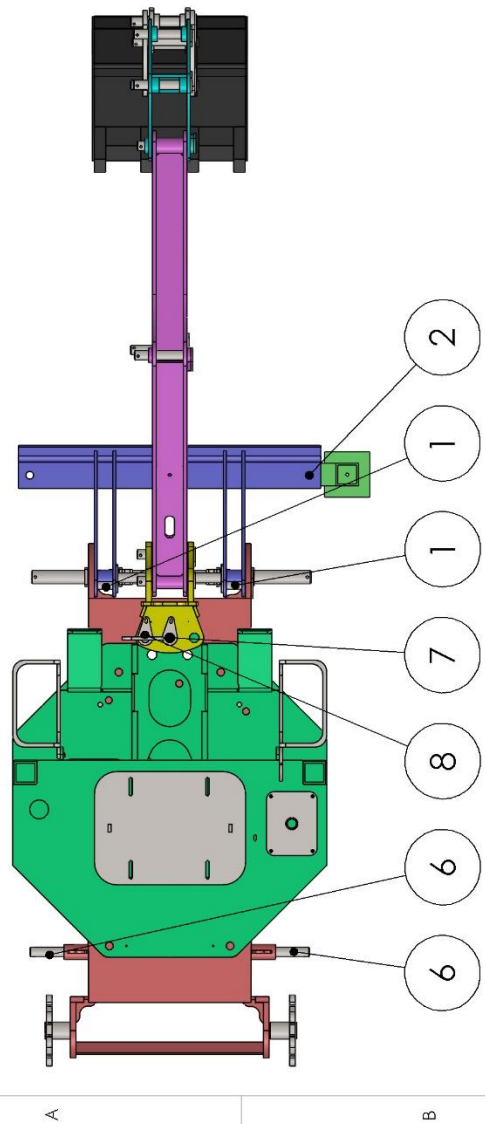

A

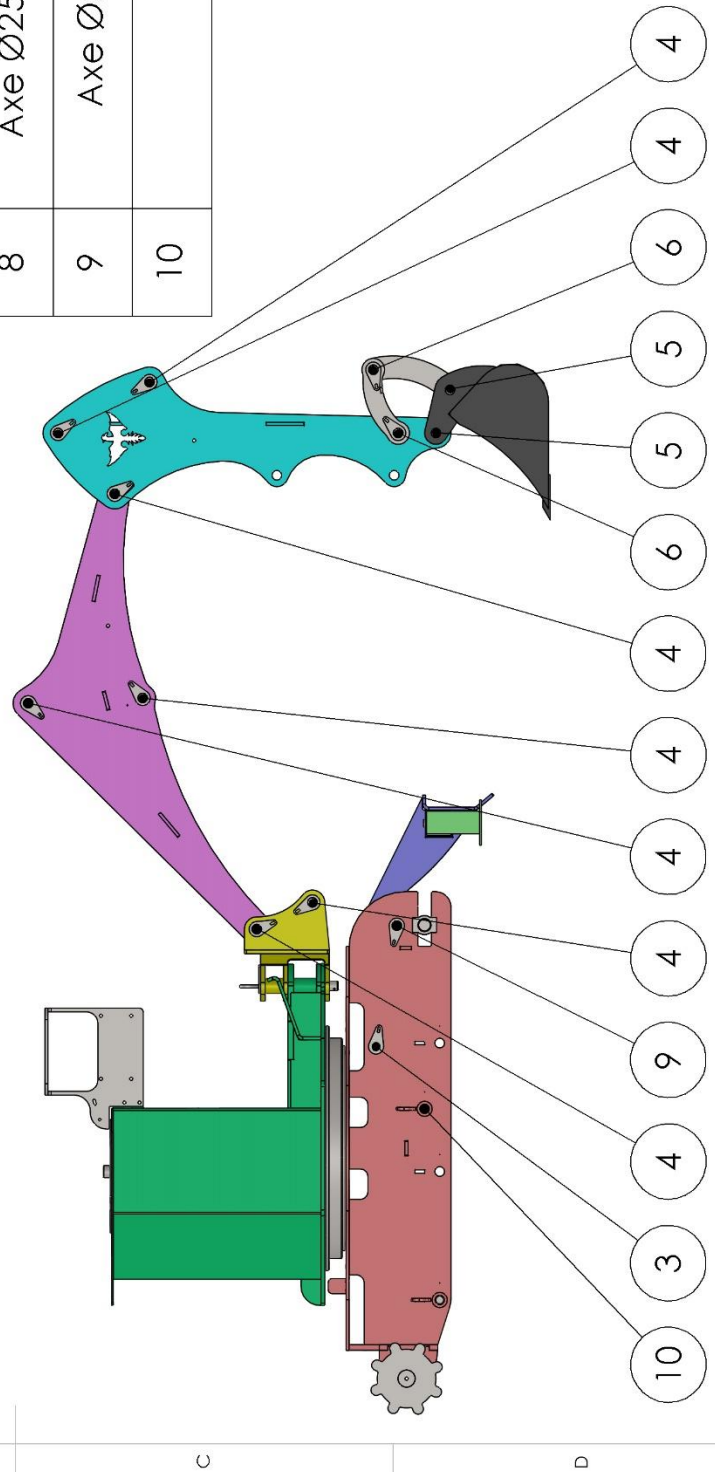

C

Ref	Designation
1	Axe Ø20 lg 60 + goutte d'eau
2	Axe Ø20 lg 90 + Rondelle
3	Axe Ø20 lg 450 + goutte d'eau
4	Axe Ø25 lg 155 + goutte d'eau
5	Axe Ø25 lg 175 + Rondelle
6	Axe Ø25 lg 175 + goutte d'eau
7	Axe Ø25 lg 210 + goutte d'eau
8	Axe Ø25 lg 210 + goutte d'eau + P
9	Axe Ø25 lg 450 + goutte d'eau
10	Axe Ø25 lg 740

B

TITRE:

Ph400 - Axes

Date:

11/04/2019

A4

Phoenix 400 Kit	Date:	Client:
	N° F/D:	

Configuration 14 cv - Kit à Souder

Option(s)

	Attache rapide	KIT / SP			Option	Push pull Godet *		
	Godet 20	KIT / SP			Option	Ligne hydrau AV *		
	Godet 30	KIT / SP			Option	Ligne hydrau AV - BT		
	Godet 40	KIT / SP						
	Godet 60 - Curage	KIT / SP			Option	Joint tournant 6 voies		
	Godet 80	KIT / SP			Option	Compte heure		
	Dent ripper	KIT / SP						
	Doigt manutention	KIT / SP			Option	Huile hydraulique 10L		
	Godet chargeur	KIT / SP			Option	Huile hydraulique 20L		
	Godet Rateau	KIT / SP			Option	Huile moteur SAE30		
	Godet squelette	KIT / SP			Option	Cartouche graisse 400 g		
	Arceau	KIT / SP						
	Toit	KIT / SP			FREINFIL-FORT	Frein fillet Serrage Fort 60G		
	Contre poids 95 kgs	KIT / SP			COLLEHYDRO	Colle hydraulique 50 ml		
	Bras télescopique	KIT / SP			RUBAN-PTFE	Rouleau Ruban téflon		
	Taille haie	KIT / SP			COLLIER-9x180	Collier installation 9 x 180		
					COLLIER-9x360	Collier installation 9 x 360		

Axes

A-20 lg 60	Axe Ø20 lg 60	2			Tube Ø42,4 ep3 lg 55	2		
A-20 lg 90-1P	Axe Ø20 lg 90 - 1 perçage	1		BA-25.25 lg 10	Bague Ø25,25 lg 10	6		
A-20 lg 435	Axe Ø20 lg 435	1		BA-25.25 lg 15	Bague Ø25,25 lg 15	4		
A-20 lg 570	Axe Ø20 lg 570	1		BA-25.25 lg 20	Bague Ø25,25 lg 20	2		
				BA-25.25 lg 41	Bague Ø25,25 lg 41	2		
A-25 lg 155-1P	Axe Ø25 lg 155 - 1 perçage	7		BA-25.25 lg 48	Bague Ø25,25 lg 48	1		
A-25 lg 180-1P	Axe Ø25 lg 175 - 1 perçage	6		BA-25.25 lg 60	Bague Ø25,25 lg 60	3		
A-25 lg 210-1P	Axe Ø25 lg 210 - 1 perçage	2		BA-25.25 lg 65	Bague Ø25,25 lg 65	2		
A-25 lg 435	Axe Ø25 lg 435	1		BA-25.25 lg 72	Bague Ø25,25 lg 72	2		
A-25 lg 740-2P	Axe Ø25 lg 740 - 2 perçage	1		BA-25.25 lg 84	Bague Ø25,25 lg 84	1		
				BA-25.25 lg 94	Bague Ø25,25 lg 94	2		
A-35 lg 740-2P	Axe Ø35 lg 740 - 2 perçage	1						

Listing acier							
LA-1045-8-D	Renfort 2 bras levée	1		LA-1314-10-A	Plateforme tourelle AV	1	
LA-1046-8-C	Renfort Bras balancier	1		LA-1315-10-B	Plateforme tourelle AR	1	
LA-1049-6-B	Calle renvoi bras	1		LA-1316-15-A	Renfort tourelle long	1	
LA-1060-4-C	Plaque réservoir	1		LA-1317-15-A	Renfort tourelle court	1	
LA-1061-15-A	Barbotin	2		LA-1318-12-A	Renfort pivot bas	1	
LA-1071-5-A	Goutte d'eau 20	4		LA-1319-15-B	Renfort pivot haut	1	
LA-1072-5-A	Goutte d'eau 25	18		PL-1320-8-A	Marche pied gauche	1	
TU-1073-3-A	Tube lame 70 lg 800	1		PL-1321-8-A	Marche pied Droit	1	
LA-1075-10-B	Goutte d'eau 25 ep 10	2		LA-1322-10-A	Plaque rotation tourelle	1	
TU-1076-5-B	Tube béquille lg 700	1		PL-1323-8-A	Support distributeur gauche	1	
TU-1077-5-A	Tube béquille lg 140	1		PL-1324-8-A	Support distributeur doit	1	
PL-1121-8-A	Lame stabilisatrice	1		LA-1325-8-B	Fixation support distri	2	
LA-1122-8-C	Fixation lame	4		LA-1326-8-A	Tenon plaque moteur	1	
LA-1125-12-B	Renvoi bras	2		LA-1327-4-A	Fixation moteur Thermique	1	
LA-1214-8-B	Poignée	1		LA-1328-4-B	Support siège	1	
LA-1215-8-C	Renfort 3 bras levée	1		PL-1329-3-C	Carter moteur	1	
LA-1265-8-A	Fixation JT	2		PL-1330-3-A	Carter réservoir	1	
LA-1266-4-C	Support JT6V	1		LA-1331-3-A	Fond réservoir	1	
LA-1271-4-A	Bouchon tube tourelle	1		LA-1332-8-A	Tenon siège	2	
TU-1272-5-B	Tube tourelle 60 lg 250-1P	2		LA-1333-4-A	Support siège	1	
LA-1305-8-C	Plateforme chassis bas	1		LA-1334-12-A	Renvoi godet	2	
LA-1306-8-A	Armature avant	1		LA-1335-8-A	Bras balancier	2	
LA-1307-15-B	Armature arriere	1		LA-1336-8-B	Bras levée	2	
LA-1308-15-C	Flasque chenille	2		LA-1337-8-C	Renfort 1 bras levée	1	
LA-1309-8-A	Gousset 55	8		LA-1338-15-A	Joue noix	2	
LA-1310-15-A	Butée basse	1		LA-1339-12-A	Pivot noix	3	
LA-1311-15-A	Fixation moteur traction	2		LA-1340-10-A	Fond noix	1	
LA-1312-6-A	Renfort moteur traction	1		LA-1341-8-A	Renfort noix	2	
LA-1313-5-B	Patin stabilisateur	1		LA-1342-8-A	Butée tendeur	4	
Général							
MOT-14CV-Kol	Moteur 14 CV Kolher	1		ROLLER 160-25	Roller 160 - 25	2	
LAG2-90	Lanterne 90 Groupe 2	1		ROLLER 240-25	Roller 240 - 25	2	
AEG2-25,40	Acc elastique G2	1		ROLLER 240-35	Roller 240 - 35	2	
PDG2-6+6-CT-D	Pompe 6 + 6 G2	1					
	Diviseur de débit 50/50	1		VD25/40C100	Vérin 25/40c100	2	
	Radiateur huile	1		VD30/50c300	Vérin 30/50c300	2	
	Support radiateur	1		VD30/60c300	Vérin 30/60c300	1	
	Cable Electrique 2 fils 1,6m	1					
	Siège avec accoudoir	1		D4-2J-40L	Distri 4 éléments 2 joy	2	
	Couronne de flexibles	1		D2-40L-CR	Distributeur D2 - Cranté	1	
COT650-M6	Couronne orientation T-pro	1		MCRN200CDO	Moteur hydro 200	3	
PIG-E-M6-12D	Pignon engrenage M6	1					
					Batterie 12v	1	
LA-1229-8-A	Plaque contre poids	5			Support batterie	1	
LA-1230-8-A	Oreille contre poids long	2					
LA-1389-15-B	Oreille contre poids court	1		180x72x43	Chenilles	2	

Carton							
Bouchon M22	Bouchon avec jauge	1			Accelérateur	1	
C3/8-p	Crépine plate	2			Plaque joint réservoir	1	
EC19M3/8	Embout cannelé 3/8	2		RC10-10x34	Caoutchouc amortisseur	4	
EC19M1/2	Embout cannelé 1/2	2		GF16	Guide Flexible double	3	
UM12L-15x21	Raccord union 15x21	10			Etage guide flexible	1	
UM12L-12x17	Raccord union 12x17	20					
CM12L-12x17CO	Raccord Coudé 12x17	4			Cable Batterie 16 ² - 25 cm	1	
T12L	Té 12L	2			Cable Batterie 16 ² - 50 cm	1	
RM1/2-F3/8	Réduction M1/2-F3/8	6		CS29-31	Collier acier	4	
RM1'-F1/2	Réduction 1" - 1/2	2			Cosses 16 ² à sertir Ø6	1	
VC17-12x17	vis creuse Ø17	18			Cosses 16 ² à sertir Ø8	3	
JC17	joint cuivre Ø17	40					
JC18	Joint cuivre Ø18	1		GR6-D	Graisseur	10	
CCM1/2	Push pull 1/2	3		GR6-90	Graisseur coudé 90	2	
CCF1/2	Push pull 1/2	3		GC006	Goupille	25	
	Rondelle ø5	4					
	Rondelle ø6	15			Vis STHC 6x10	1	
	Rondelle ø8	25			Vis 5/16 x1"1/4	4	
	Rondelle ø8 x 30	2					
	Rondelle ø8 x 40	15			Vis 6x25 BTR	8	
	Rondelle ø12	4			Vis 6x60 BTR	2	
	Rondelle ø18	11			Vis 8x20 BTR	8	
	Rondelle ø20	2			Vis 5x20 TH	2	
	Rondelle ø25 ep 1	10			Vis 6x16 TH	20	
	Rondelle ø25 ep 4	6			Vis 8x30 TH	12	
					Vis 8x40 TH	1	
					Vis 8x50 TH	2	
	Ecrou M5 stop	2			Vis 8x60 TH	11	
	Ecrou M6	2			Vis 8x100 TH	1	
	Ecrou M6 stop	4			Vis 12x20 TH	2	
	Ecrou M8 stop	30			Vis 12x30 TH	19	
	Ecrou M12 stop	6			Vis 12x50 TH	6	
	Ecrou M16	4			Vis 16x100 TH	4	
	Ecrou M18 stop	11			Vis 18x50 TH	9	
	Ecrou M20 stop	1			Vis 18x70 TH	1	
	Ecrou M20	1			Vis 18x120 TH	1	
					Vis 20x80 TH	1	
	Ecrou M16 long	4					
	Bossage M22 a souder	1					
US-1154-A	Bague clavetée	2					